

STACKER[®]

INDUSTRIAL GRADE 3D PRINTERS

User Guide

MODEL 500 (2015-KS)

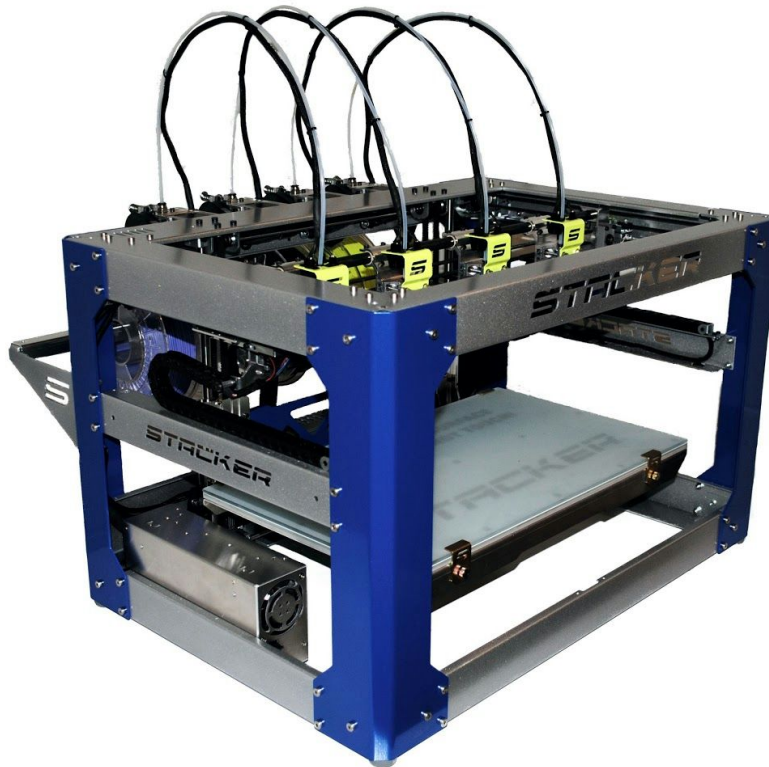

©Copyright 2016 **STACKER, LLC**

Minneapolis, MN 55427

<http://stacker3d.com>

STACKER[®] is the registered trademark of **STACKER, LLC**.

Revised: 20 February 2016

User Guide

MODEL 500 (2015-KS)

TABLE OF CONTENTS

- 1. Introduction**
- 2. Warnings**
- 3. Unpacking and Final Assembly**
 - 3.1. Locate Hardware boxes & Filament Rail
 - 3.2. Universal Filament Rail Installation
 - 3.3. Filament Drive Idler Assembly Hardware Installation
 - 3.4. Final Tape Removal
 - 3.5. Cable Ties
 - 3.6. Blower Fans
- 4. Download STACKER RUN Software**
- 5. Printer Set-up**
 - 5.1. Power Up Printer
 - 5.2. Level The Print Bed
 - 5.3. Adjusting Nozzle Height
 - 5.4. Changing Nozzles & Filament Guide Tube
 - 5.5. Loading Filament
 - 5.6. Manual control via STACKER RUN
 - 5.7. SD Card Printing
 - 5.8. First Print
 - 5.9. Multi-Part Printing
 - 5.10. Multi-Material Printing
 - 5.11. Slicing Engine
- 6. Turning Off your Printer**
- 7. Volumetric Calibration**
- 8. Calibration of x/y/z axis**
 - 8.1. Vref Settings
- 9. Useful Info**
 - 9.1. Power Supply Data Sheet
 - 9.2. Installing the LCD Smart Controller
 - 9.3. Filament Settings Guide
- 10. Terms and Conditions**

1. Introduction

The STACKER Model 500 is a high performance 3D printer capable of producing everything from one-off prototypes to multiple part production runs. To get the most out of your printer, please read through this User Guide before operating.

It is also helpful to be familiar with solid modeling CAD applications in order to create and manipulate the parts you want to print. For example, a simple design modification or splitting a model into sections will allow you to print it faster, better, and without the need for support materials. The following list of CAD apps is a good balance of power and value, some of which are free and have robust online training and user communities. Nearly all of these apps will export your models to the preferred .stl file format.

- Sketchup
- Autodesk 123D apps - including Meshmixer and Tinkercad
- openSCAD, netfab studio basic, Geomagic Design
- Fusion 360, SolidWorks, Inventor, Solid Edge

Before making your first prints you will be directed to download software and view online training materials at the locations below.

- Printer setup support <http://stacker3d.com/kickstarter-support>
- **STACKER RUN** software download <http://stacker3d.com/kickstarter-support>
- **STACKER RUN** documentation <http://www.repetier.com/#documentation>

2. Warnings

STACKER 3D printers are industrial machines that should never be operated around children or left unattended. Careful setup and training is required for optimal results. Read through this guide and view online resources before turning on your printer.

Note, this printed copy of the User Guide may not be the most current version. We recommend downloading the User Guide from our website to confirm you have the latest version. The revision date is noted on the cover page.

Please read and take seriously all Warnings. Unsafe operation of a 3D printer can result in damage to your printer and serious injury to yourself. The Warnings pages are included in the box with every printer and are also available at this website address:

- <http://stacker3d.com/kickstarter-support>



Burn Hazard! Do NOT touch hot surfaces!

Both the hot ends and heated bed can get HOT! Although the HYBRID hot end comes with a stainless steel shield around the heater block assembly, a small portion of the nozzle is still exposed and can severely burn you. To prevent burns, avoid touching the hot surfaces of the 3D printer.



Fire Hazard!

Never place flammable materials or liquids on or near the printer. It is your responsibility to operate your printer in a safe manner. To ensure that it is safe, you must incorporate the use of fire and smoke alarms and proper fire suppression technologies like fire extinguishers. **Never operate the printer unattended.**



Static Charge and Electric Shock Hazard!

Ground yourself before touching the printer. Static charge can damage your printer's electronic components. Discharge your static before touching your printer! Also, the printer must be kept dry. Attempting to operate the printer in a wet environment will damage your printer and could lead to injury. Always power down and disconnect the power cable from your printer before servicing or opening your controller housing.



Pinch Hazard! Keep Hands and Fingers Clear.

During operation, the X/Y gantry and bed will perform quick and sometimes unpredictable movements. To avoid injury, never place your hands, fingers or body near any moving parts of the printer including belts, pulleys, and hot ends. Be sure to tie back long hair and remove any clothing or jewelry which could become caught in the moving parts of the printer.



Age Warning.

For users under the age of 18, adult supervision is recommended. Small printed parts can become a choking hazard for small children. **Never operate the printer unattended!**

3. Unpacking and Final Assembly

If you have a STACKER 500 Desktop model, you must first complete all the steps of the page titled “Unboxing Assembly Instructions for Desktop Model 500.” If this page was missing from your printer please download it here:

- <http://stacker3d.com/pdf/desktop-start-stkr500ks.pdf>

If you have a full height model that arrived on a pallet, carefully cut away the packaging and set the unit upright on its casters.

3.1. Locate the two hardware boxes and universal filament rail

Two small boxes and the Universal Filament Rail are either located at the bottom of your box if you have the desktop model or attached to your printer with stretch wrap on full height models.

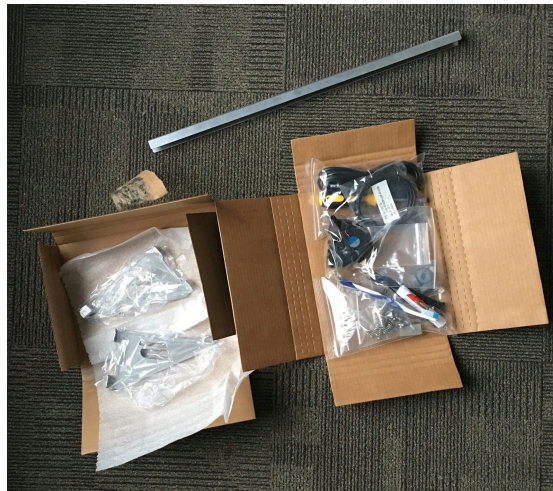

Box #1 contains the Right and Left Universal Filament Rail Brackets, shown below.

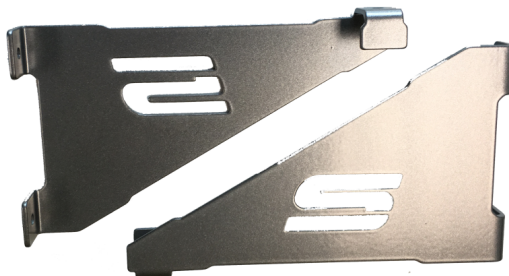

Box #2 contains three main hardware bags:

Hardware Bag #1



Hardware Bag #2*



*Note, 2 head models will only contain hardware for a single blower fan

Hardware Bag #3



*Note, 2 head models will only contain half the hardware shown; enough for their two filament drives.

3.2. Attach the universal filament rail assembly.

Step 1. Locate the Universal Filament Rail, the two Filament Rail Brackets, and the two Filament Rail Screws.

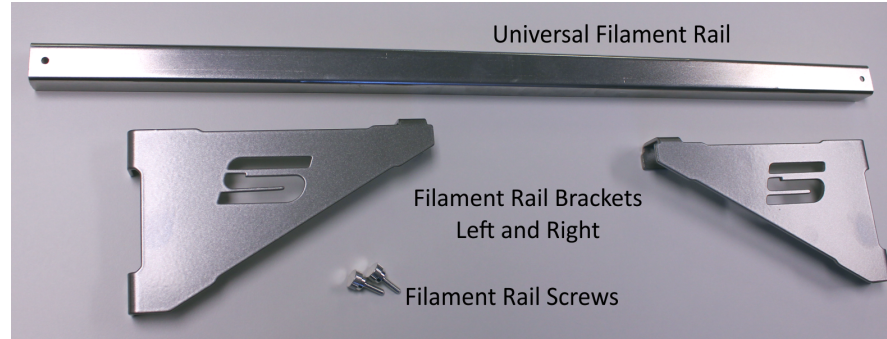

Step 2. Remove the four 5mm x 16mm Socket Head Cap Screws that also secure the plastic wire harnesses clamps (see photo below). These screws are located on the blue colored corner brackets. You will reuse these screws to mount the Filament Rail Brackets in the next step. Use the supplied 3mm hex wrench and an 8mm wrench/socket/pliers (not provided).

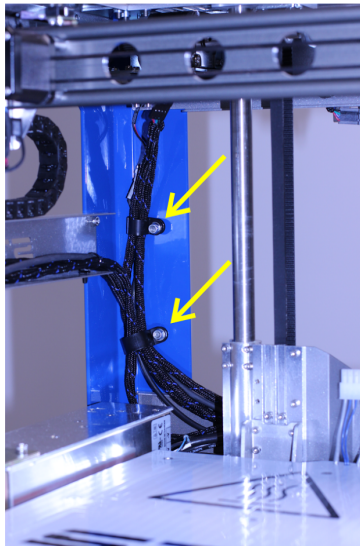

Step 3. Attach the filament rail brackets using the hardware you removed in the prior step. Note the orientation in the image below. Also, make sure all four screws go back through the wire harness clamps. Failure to secure the wire harnesses could result in serious damage to your printer during operation. Repeat the installation on both the right and left sides of the printer.

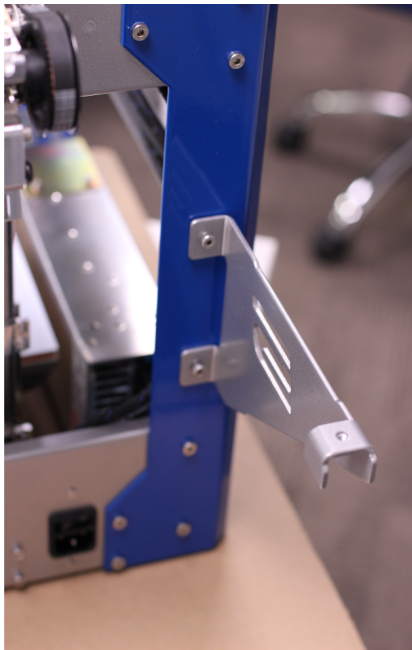

3.3. Install the filament drive hardware.

Step 1. Locate the filament drive idler assembly hardware. Each filament drive requires (2) compression springs, (2) M4 x 30mm Socket Head Cap Screws, and (2) M4 Thumb nuts, as shown. Note the red coating on the Screws, this red coating will prevent the thumb nuts from backdriving.



Step 2. Attach the filament drive idler assembly hardware to each of your printer's filament drives, as shown below. The small knobs should be flush to the end of the screws. Use the supplied 3mm hex wrench to hold the screws while you hand tighten the knobs.

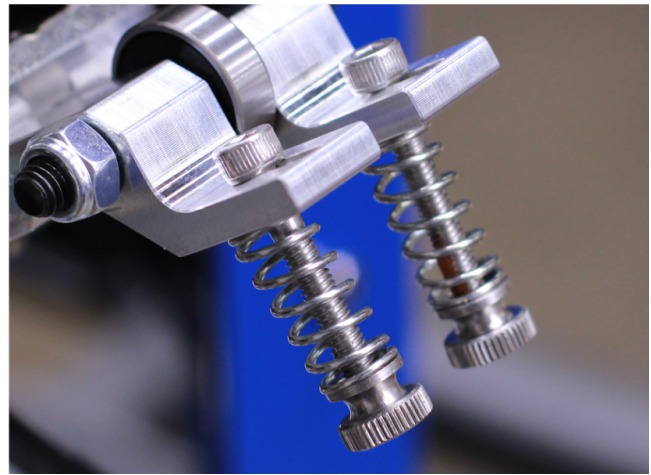
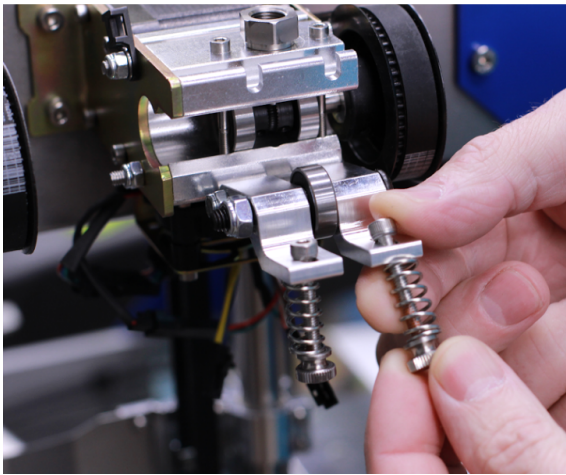

3.4. Remove the packaging tape.

To protect your printer during shipping, we attached several pieces of low tack tape to the X gantry, Y Shaft, Z Shaft, and glass bed. You **MUST** remove all of this packing tape before continuing. Clean off any residue with an alcohol wipe, if necessary.

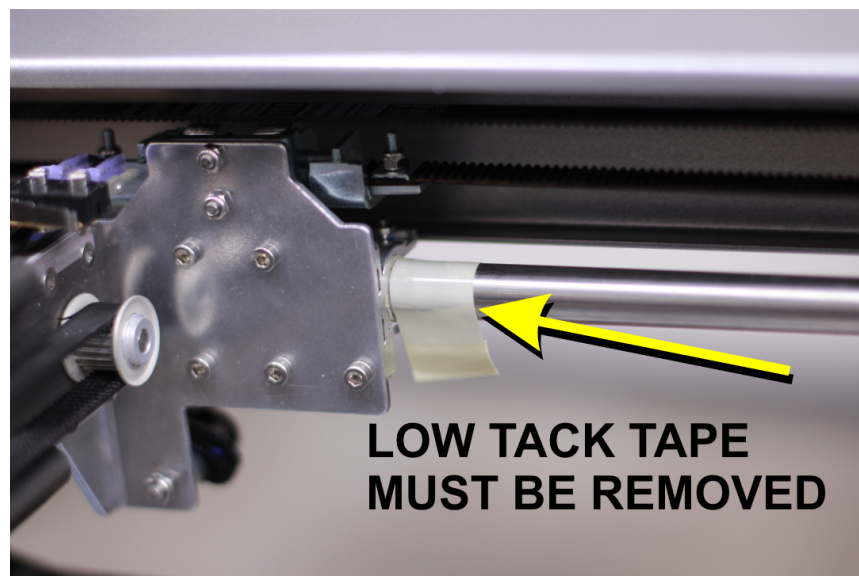

3.5. Attach the cable ties on your filament guide tubes.

Use the supplied zip ties to secure the wire harnesses and guide tubes together, as shown below. Use four ties per guide tube - three as shown and one zip tie through the special bracket mounted on each filament drive.

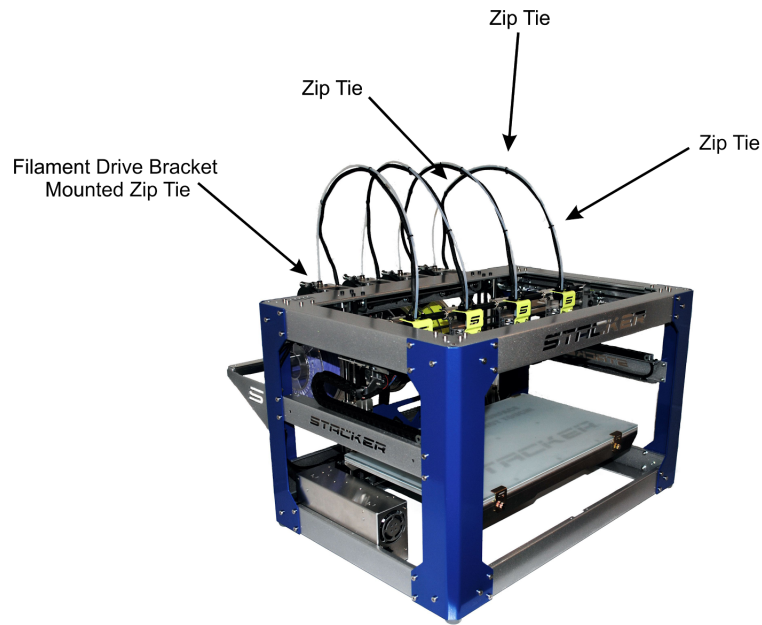

3.6. Attach the blower fans.

Your STACKER comes with one or more 50mm blower fan pre-installed at the factory for testing purposes. Please use this pre-installed fan as a reference to install your other blower fans. **It is critical that your blower fans are positioned correctly during the operation of your printer!** If the fans are positioned in the incorrect position (see images below), the blower fans will crash into the frame of your printer when you home the Y axis. To prevent possible damage to your printer, be sure to lower the fans and keep them correctly positioned.

Blower Fan **Incorrectly** Positioned!

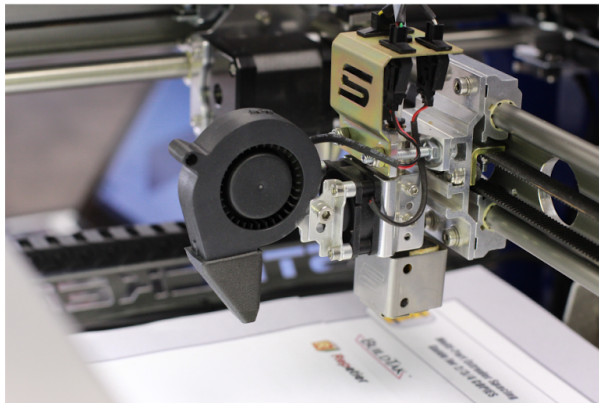

Blower Fan **Correctly** Positioned.

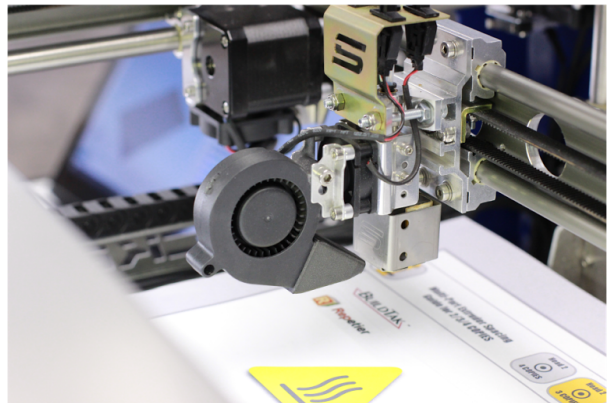

IMPORTANT! The blower fan will crash into the printer's frame if incorrectly positioned.

Attaching the Blower Duct: The images above show the 50mm blower duct attached to the fan. These blower ducts were not included with your printer, but an STL file of the blower ducts is available on our website, so you can print your own: <http://stacker3d.com/kickstarter-support>

When attaching the blower duct, make sure it is attached with the proper orientation, otherwise the blower duct can crash into the bed when homing the Z-axis.

Our blower duct prints a "T" on the top of the duct to help identify the top.

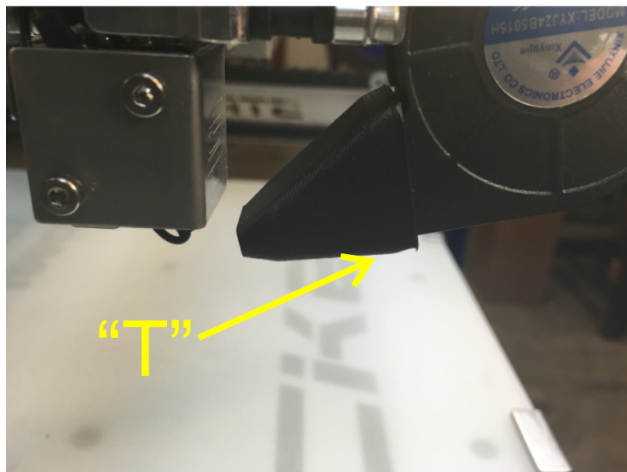
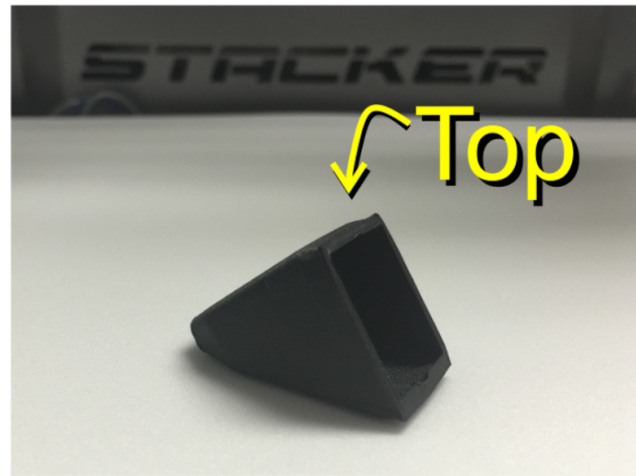
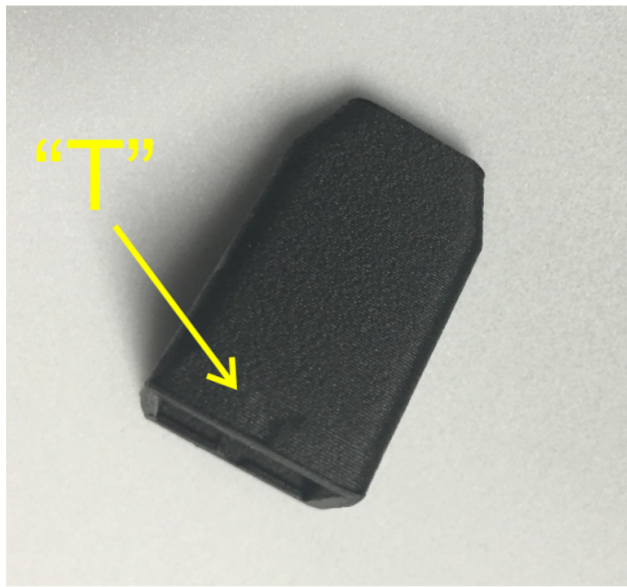

Incorrect!
Bower Upside Down

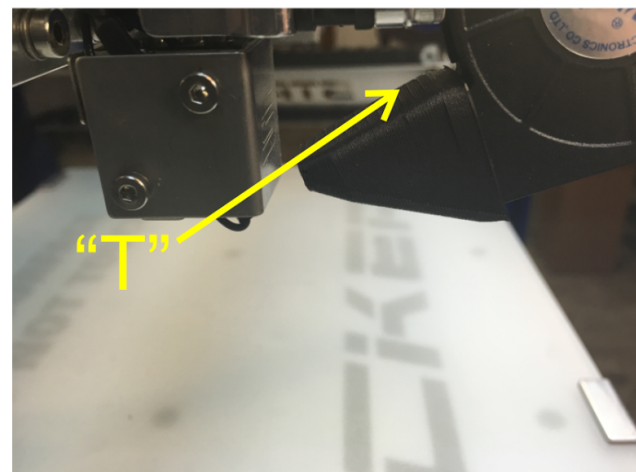

Correct

If the blower duct is installed upside, it can crash into your bed when homing the Z-axis. If you choose print and install blower ducts, be sure that they are installed correctly.

4. Download STACKER RUN software



Before turning on your printer, please download **STACKER RUN** software. It is available for download from our Kickstarter Support Page.

- <http://stacker3d.com/kickstarter-support>

Download **STACKER RUN** and follow the installation instructions. Built into the program are other online resources for learning how to use this software. Please familiarize yourself with the software before continuing.

STACKER RUN software is an enhanced version of Repetier Host, so most of the documentation available from their website will be highly applicable. You should also pay note to the instruction manuals available here:

- <http://www.repetier.com/documentation/repetier-host/rh-installation-and-configuration/>

5. Printer Setup

5.1. Power Up Printer

Before you turn on your printer you must connect the power cord and USB cable.

Your printer ships with a North American 10 amp cord with a C13/14 connector. This is a common “computer” type power cord. The C13/14 plug is widely available almost anywhere in the world to fit your specific power outlets. If you are not using North American 115v AC power and outlets, please purchase a proper cord at your local computer or electronics store.

Note: the power supply can accept 115 to 230 volts of AC power. The power supply is auto switching which means that it will internally adjust to your outlet’s voltage automatically. We have attached a data sheet for this power supply to help you properly connect it to your power source and determine compatibility. Please reference this data in Section 9.1.

We also strongly recommend using an uninterruptible power supply (UPS) with your printer. Any sudden loss of power, no matter how brief, will likely cause the electronics in this printer to reset, and this will ruin your print. If you want to prevent the pain and suffering associated with losing a multi-hour long print, then we recommend a UPS. Furthermore, power spikes and brownouts can damage the printer’s electronics. Any good quality UPS will save you from momentary power loss or brown outs. We cannot stress enough the importance of this very inexpensive insurance. Uninterruptible power supplies (UPS) are widely available at your computer or electronics store.

The provided USB cable connects your printer to a computer. Please connect the USB cable to the controller housing as shown.



Your printer is powered on by utilizing the power switch located directly above the C14 power inlet for your power cable.

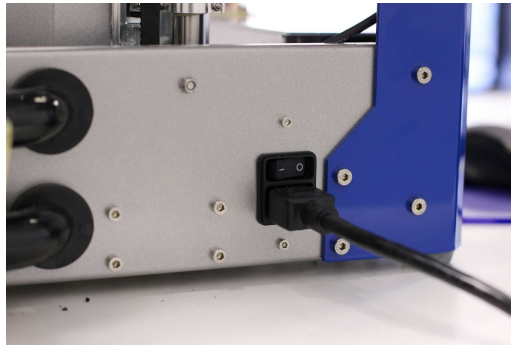

Before turning on your printer for the first time, confirm that the USB cable is installed correctly and that your **STACKER RUN** software is up and running on your computer.

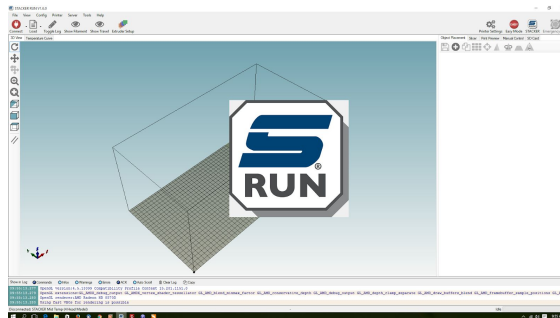

5.2. Level The Print Bed

Your bed is pre-leveled at the factory which enables us to make a test print. During shipping your bed leveling can change, so you need to make sure your bed is level. We give you an aluminum setup block to help you safely level the bed without crashing your print heads into the glass. For most users the bed will still be level, and all you will have to do is perform a final test.

If your bed is way out of adjustment you will need to follow the full adjustment process. You begin this process by homing the z-axis on the aluminum setup block, and then you level the bed to the nozzles. Then, you home the z-axis on the setup block again to adjust the gap between the now level bed and the nozzles. Finally, you home the z-axis without the setup block and do a final test with a business card, a 0.007" feeler gauge or a 0.20mm feeler gauge. Micro adjustments will be made with the adjustment knob on the z-probe.

Leveling your print bed is a **mandatory first step** before you can print. If the bed is too far away from your nozzle the print will not stick to the build plate. If the nozzle is too close to the build plate it will prevent the filament from flowing out of the nozzle, and this will eventually cause the filament to jam because the filament will strip out inside the filament drive.

VIDEO ALERT! Please watch the short video “Bed Leveling” located on our Kickstarter Video Support Page.

- <http://stacker3d.com/kickstarter-video-page/>

FULL ADJUSTMENT PROCESS

Step 1. Connect your printer to STACKER RUN software. Click the Connect button located in the upper left corner. A drop down menu will allow you to select the correct model, as shown by the arrow.

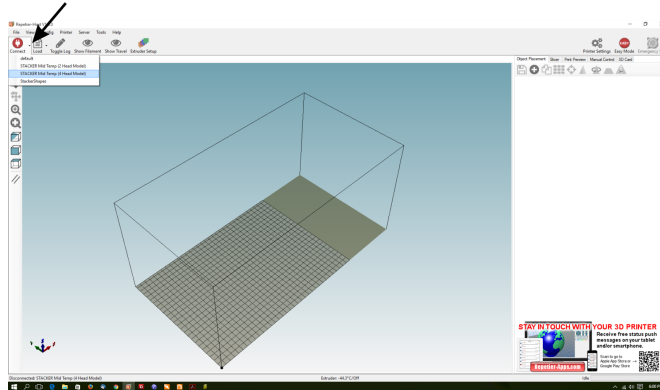

Step 2. Home the Z axis on the aluminum setup block.

Place the aluminum setup block under the z-probe adjustment screw BEFORE homing the z-axis, as shown below.



Next, open the Manual Control Tab and press the Z-home button  in **STACKER RUN**.

NOTE: You must use the setup block under the z-probe as shown above. **If you do not use the block, you could crash your bed into the nozzles and cause damage to your printer.**

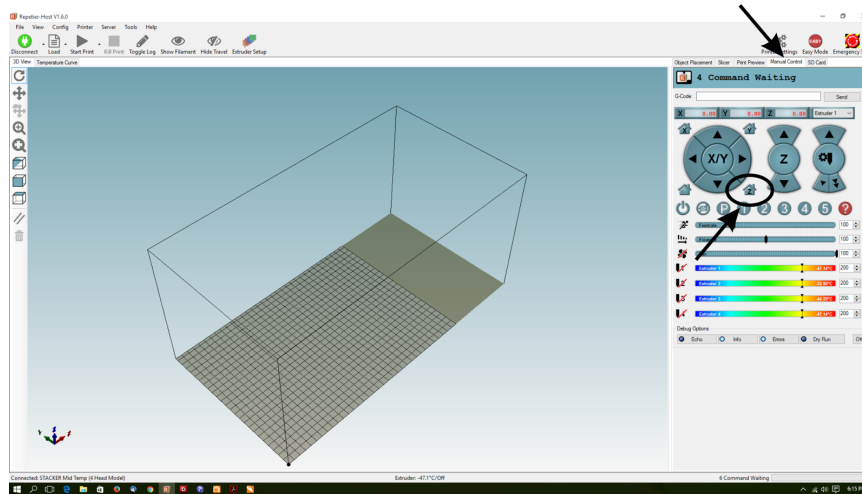

IMPORTANT: The supplied setup block is only used during bed leveling! Once the bed is level, you do NOT use the block when homing the Z bed prior to printing.

In the next step you will remove the block from under the z-probe and move the block to different locations on the bed. The setup block is used as a gauge to set the bed to the same plane as the nozzles. You are not “leveling” the bed with a level. You are setting the bed to the same plane as the x/y gantry.

Step 3. Move the X/Y gantry to the back of your print bed and position the heads, as shown below. The preferred method for moving the gantry is via Manual Control. Press the button until the gantry has moved to the back.

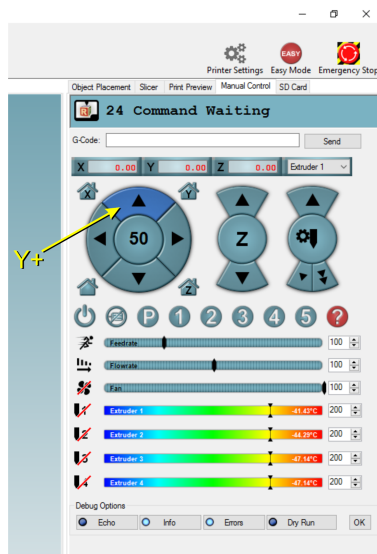

Position heads one and two on the left side of the gantry, and if you have a 4-head model push heads three and four to the far right side of the gantry, as shown below. **You use head 2 for leveling the bed.**

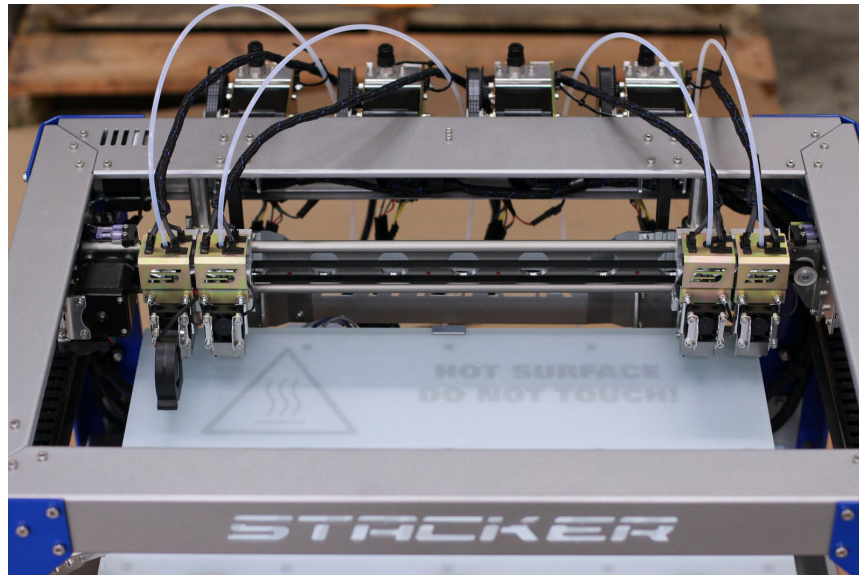

Step 4. Adjust the two back levelling screws. Move the setup block and try to slide the block and card under the nozzle of head 2. If your nozzle is more than .100" or 2.5mm above or below the setup block (which is unlikely) you may need to adjust the z-probe screw or z-probe bracket; these adjustment procedures are at end of this step, should it be necessary.

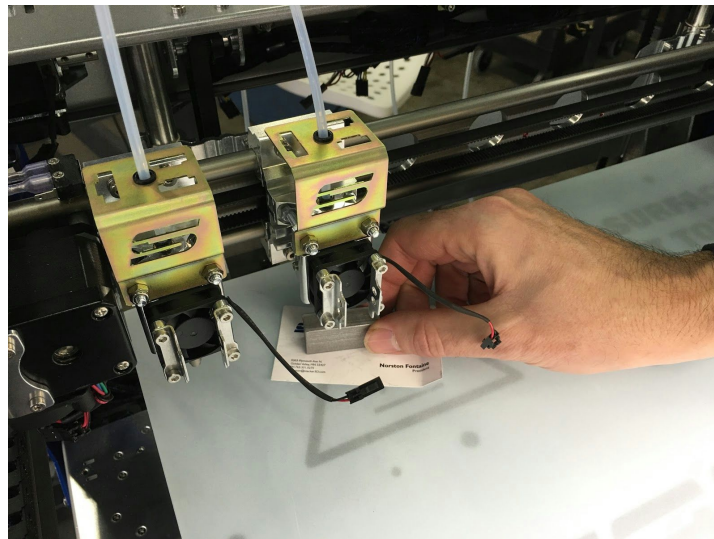

Begin by adjusting the back left leveling screw (found underneath the bed) with the supplied 7mm nut driver. Note: There are three leveling screws with heavy duty springs. When you adjust the leveler you are actually moving the 4mm hex nut. For now, only adjust the left back leveling screw. Turn the nut driver clockwise or counterclockwise until the block and business card slide under the nozzle. The block should make slight contact with the nozzle tip.

Next, slide head 2 to the far right of the gantry, as shown below. Adjust the rear right leveling screw until the nozzle makes slight contact with the setup block, just like you did on the left side.

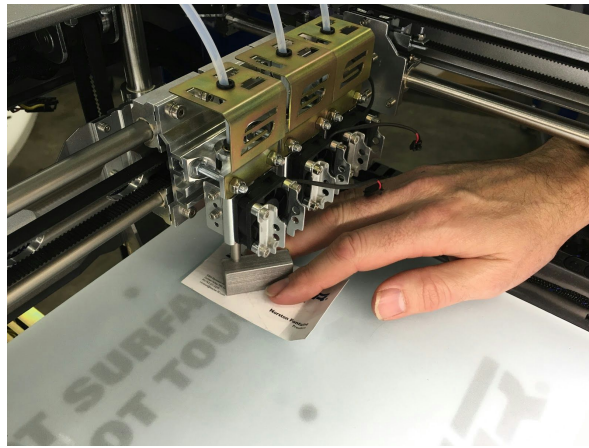

Next, slide head 2 back to the left side of the gantry and repeat the leveling process. Finally, slide head 2 to the right again, and once again, repeat the leveling process.

Z-Probe Height Adjustment Screw. See section 5.7 later in the guide.

Z-Probe Bracket Adjustment. When leveling your bed, it is possible to run out of travel on your z-probe height adjustment screw and/or your leveling springs. If this happens, you can make macro height adjustments by moving the entire z-probe bracket up or down, see below.

IMPORTANT: If you make any adjustments to the Z-probe bracket or height adjustment screw, go back to Step 2!



Step 5. Adjust the front Leveling Screw. When the back area of your bed is level, move the gantry all the way to the front by homing the Y axis.

MAKE SURE YOUR BLOWER FANS ARE DOWN AND IN THE CORRECT POSITION!

Press the  button in the manual control tab in **STACKER RUN**. **Only home the Y axis!** Now that the heads are all the way to the front of the bed. Now, place head 2 in the center front of the bed. As before, use the setup block while adjusting the leveling screw so that the nozzle makes slight contact with the block.



Step 6. Move the gantry back to the rear and readjust if necessary. Repeat the leveling process in Step 4, but you should only need very small adjustments, if at all.

Step 7. Final check and adjustment with setup block. You must now rehome the z-axis on your setup block and retest the levelness. Fine adjust, if necessary. Use the same procedures as steps 5 and 6 above. **IMPORTANT!** If you need to adjust the gap between the now level bed and the nozzles you need to adjust the z-probe mounting bracket up or down accordingly. See above.

Step 8. Final check and adjustment with business card, a 0.07" feeler gauge, or 0.20mm feeler gauge. You must now rehome the z-axis without the setup block. Use a business card or feeler gauge to check the gap between your bed and nozzles.

IMPORTANT: to dial in the perfect layer height, simply turn the adjustment screw on the z-probe and rehome the z-axis. See section 5.7 First Print for more details.

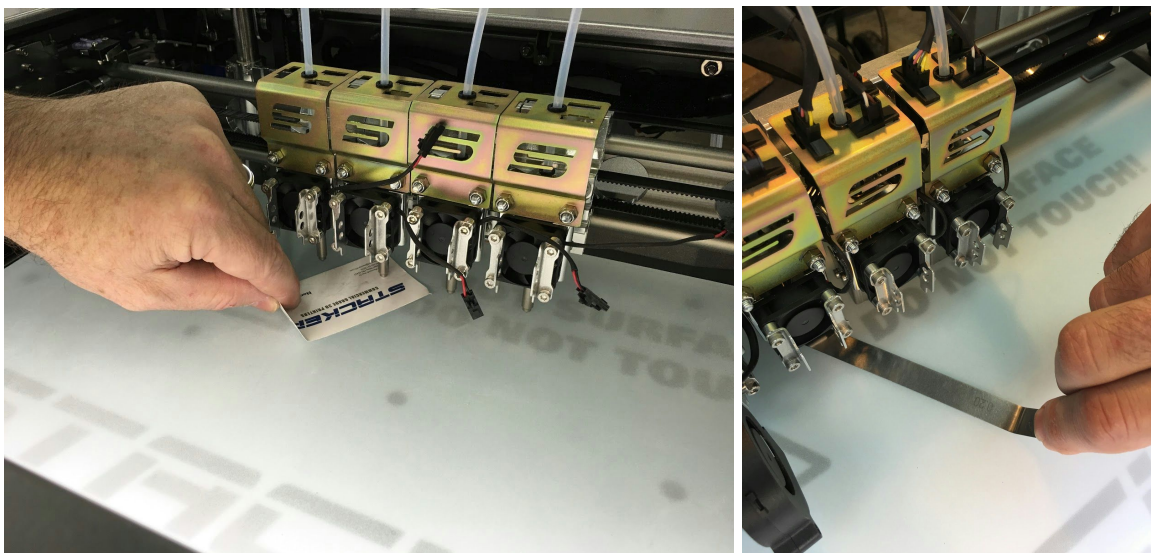

5.3. Nozzle Height Adjustment.

All the nozzles must be at the same height. However, during the leveling process you may discover that one or more of the nozzles needs a slight up or down adjustment. The easiest way to adjust is the nozzles is to rehome the Z-Axis, and use a business card or 0.07"/0.20mm feeler gauge. Note, this method only works if your bed has been leveled.

Use the supplied 7mm nut driver to loosen the two nuts on the front of the hot end, shown below. Loosening these two nuts will enable you to move the entire hot end up or down accordingly. Allow the nozzle height to be set by the thickness of the business card or feeler gauge. When retightening the two nuts, be sure to move back and forth between the two nuts and tighten them gradually and equally. Do not overtighten!

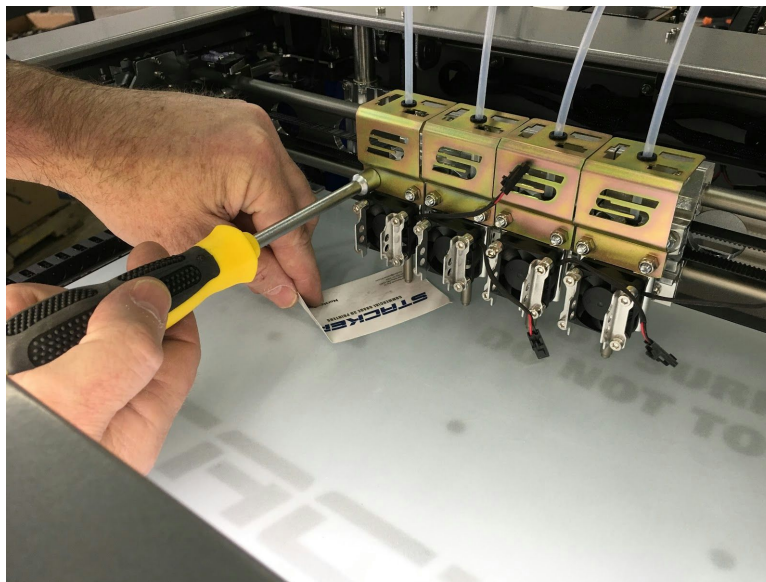

5.4. Changing Nozzles & Filament Guide Tube

Your new STACKER printer comes with four 0.50mm mid temp nozzles and guide tubes pre-installed at the factory. To get printing right away you only need to install the filament guide tube into the filament drive and load filament.

The following steps will instruct you on how to properly remove and reinstall new nozzles and filament guide tubes. Please follow these steps VERY CAREFULLY. Your nozzles will not work properly if the guide tubes are not properly seated into the nozzles.

VIDEO ALERT! Please watch the short video “Changing Nozzles and Filament Guide Tubes” located on our Kickstarter Support Page under STACKER 500 Training Videos.

- <http://stacker3d.com/kickstarter-support>

A. Remove Nozzles

Although you will not need to change nozzles for your first print, it is important to understand how to install and remove nozzles, especially if you intend on changing nozzle sizes.

Step 1. Remove the filament from your hot end and clean up any residual filament around the tip of the nozzle. Open **STACKER RUN**, connect, and go to the manual control tab. Turn on the hot end for the nozzle you wish to change to about 220°C. Once hot, release the filament drive idler assembly and pull back the filament by hand until it is clear of the hot end nozzle, about 100mm or until you can see the end of the filament through the guide tube just above the hot end.

Next, take a dry cotton cloth and wipe off the tip of the nozzle until it is clean. **Use a glove to protect yourself from getting burned.** After the nozzle is clean, **TURN OFF THE HOT END** and wait for it to cool.

IMPORTANT: Turn off the heat and wait until the hot end has cooled down before proceeding with the next step!

Step 2. Remove the guide tube from the nozzle. Use the supplied nozzle wrench to release the grip on the push-type fitting on the top of the hot end heat sink, see photo below. With the fitting compressed, gently pull on the filament guide tube until it releases from the nozzle. Pull it all the way out of the hot end and go to step 3. If the filament guide tube is stuck, go to step 2a.

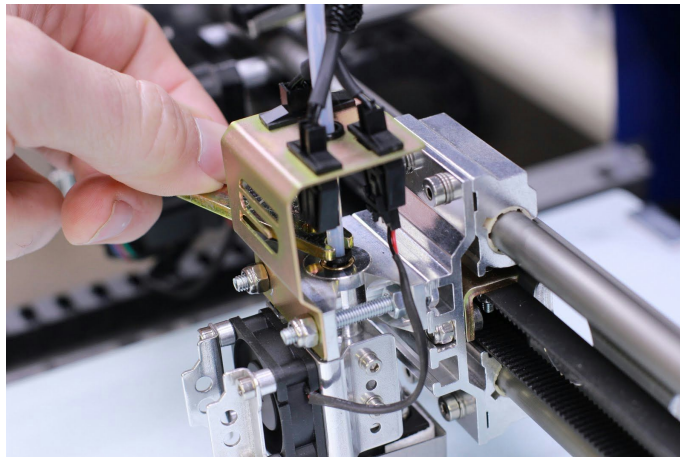

Step 2a. What to do if your tube is stuck. If the guide tube is stuck into the nozzle you must remove the nozzle and guide tube **TOGETHER**. Start by releasing the guide tube from the fitting on the filament drive. Depress the push-fit type fitting with your fingers and pull the filament guide tube out of the fitting, as shown. Proceed with the next step.

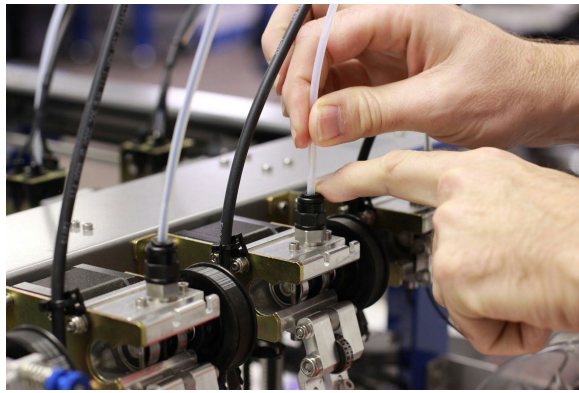

Step 3. Remove the heater block assembly. First disconnect the electrical connector with your fingers by pressing down on the tab and sliding off the connector. **DO NOT USE A PLIERS** because pliers can easily damage these plastic connectors.

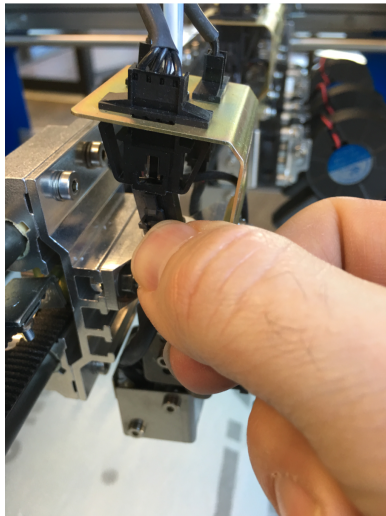

Next, using the 1.5mm hex wrench, loosen the two heater block screws on the right side of the block that clamp on to the nozzle. The heater block should easily slide off the nozzle. If not, loosen the two screws a little bit more until it slides off. Be careful the heater block does not drop on the glass bed or land on the floor!



Step 4. Remove the nozzle. To loosen the nozzle from the heat sink, use the supplied nozzle wrench. Once the nozzle is loose, you can turn it with your fingers to remove it the rest of the way. If the filament guide tube is still connected to the nozzle (Steps 2a, 2b), no worries. Just let the tube rotate along with the nozzle as you unscrew it with the wrench. If the tube cannot rotate, you may need to loosen or remove the zip ties that connect the tube to the hot end wire assembly. Once the nozzle is removed from the hot end, twist and turn the guide tube until it can be removed from the nozzle.

SPECIAL NOTE ON FILAMENT GUIDE TUBES. After many hours of use the filament guide tube may degrade and get stuck inside the nozzle. If the tube becomes stuck, use a pliers to remove it, and then trim the damaged portion of the tube above the point where you gripped it with the pliers. You can usually trim the end of the tube once or twice before the tube becomes too short for use. Also, we recommend trimming the end of your tube with a sharp knife to ensure the end of the tube properly seals within the nozzles. Make absolutely sure your trim cut is perfectly square. When in doubt, purchase a new Filament Guide Tube (p/n 90-101) from STACKER.

B. Install Nozzles

Step 1. Hand screw the nozzle all the way into the heat sink by hand until it is fully seated.

Then, reverse (loosen) the nozzle ONE AND SEVEN-EIGHTHS REVOLUTIONS. This is very important as this will tighten the filament guide tube into the nozzle in the next step, and also eliminates the “play” in the fitting on top of the heat sink.

Step 2. Insert the guide tube. Be sure the end of the filament guide tube is cut square and in new condition. If not, recut the tube with a sharp knife so that it is square. Install the filament guide tube by pushing it all the way into the hot end until it seats deep into the nozzle. Make sure the tube has been pushed all the way down into the nozzle! If the guide tube is not seated within the nozzle, problems can occur with filament extrusion.

To make certain you have seated the filament guide tube all the way into the nozzle we have designed a distance ruler into the nozzle wrench. You can use this ruler to pre-mark your guide tube. For mid temp nozzles, the distance is approximately 57mm. (seating the tube into high temp nozzles is rarely a problem).

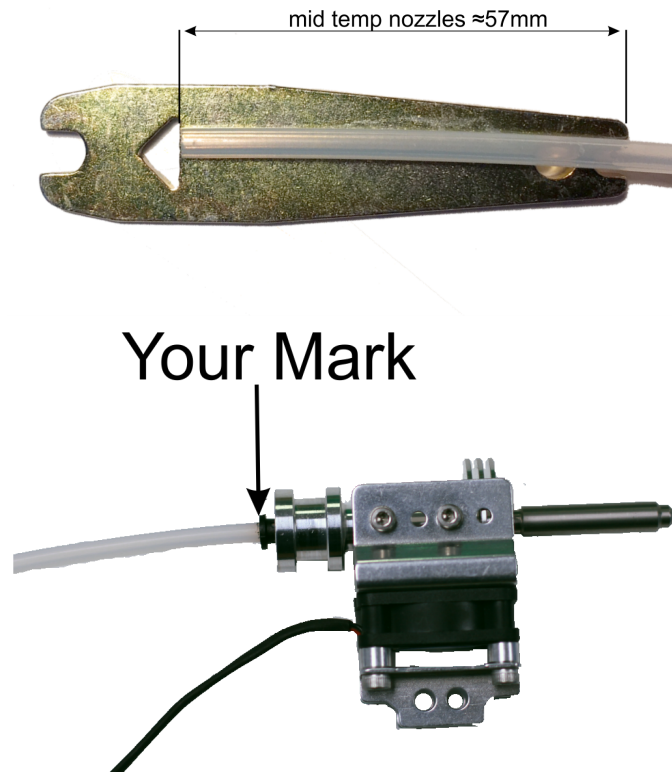

Step 3. Tighten the nozzle. When you are certain that the filament guide tube is seated in the nozzle, use the nozzle wrench and tighten the nozzle, snugly. Do NOT overtighten. The filament guide tube should rise as you tighten the nozzle. As the tube rises, it will tighten on the push-type fitting. Your guide tube must not have any “play”. To test for “play”, simply grasp the tube and try moving it up and down. If the tube moves up and down, even a little bit, go back to step 1 and carefully redo each step again.

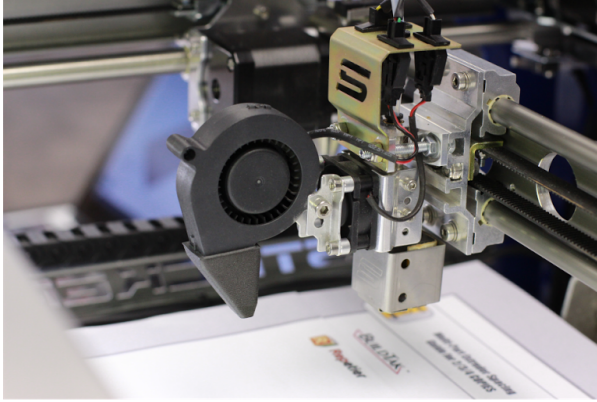
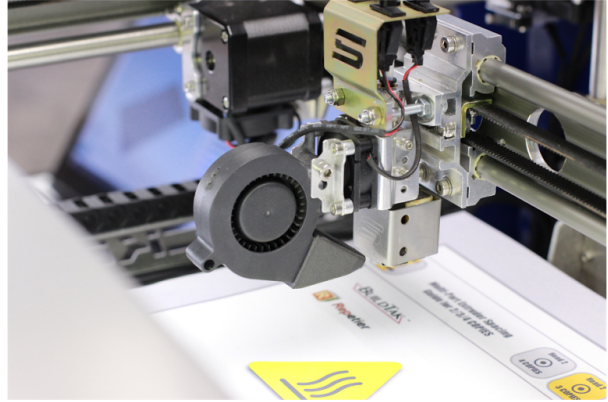

It is common practice to move the blower fan out of the way when changing nozzles. **Be certain to return the blower fan to the correct position to avoid damaging your printer!**

Blower Fan **Incorrectly** Positioned!Blower Fan **Correctly** Positioned.

C. Insert guide tube into the filament drive.

Step 1. Hand screw the black guide tube fitting until tight. Then, reverse (loosen) the fitting TWO AND A HALF REVOLUTIONS. This is very important as this will tighten the filament guide tube into place and eliminate the “play” in the fitting.

Step 2. Insert the guide tube and tighten the fitting. First, push the tube in all the way! Then, gently pull the tube out with one hand until it catches on the fitting while using your other hand to tighten the fitting, see image below. The tube must not have any “play”. To test, simply grasp the tube and try moving it up and down. If the tube moves up and down within the fitting, start over.

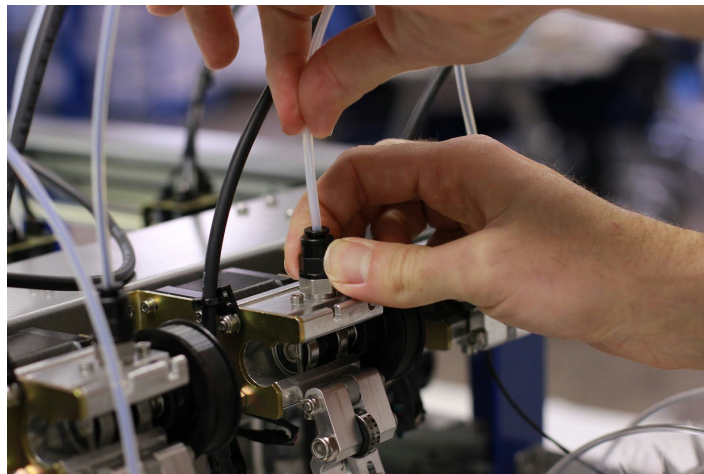

5.5 Loading Filament

Step 1. Load the spools. Loosen and remove both Universal Filament Rail knobs. You can usually lift just one side of the Rail to load spools of filament, while the other end of the rail remains engaged with the bracket. After your spools have been placed upon the Universal Filament Rail, reattach the Filament Rail knobs to secure the rail in place if necessary.

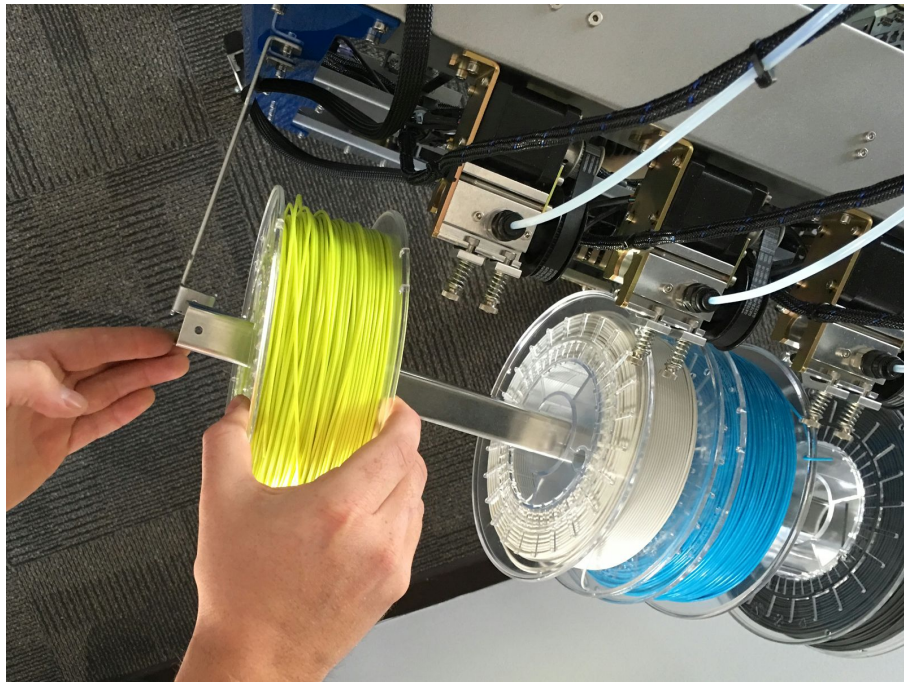

Step 2. Insert the filament. With the filament drive idler assembly open, insert the filament upward through the small hole beneath the filament gear, then push the filament upward past the gear and through the filament guide just above the gear.

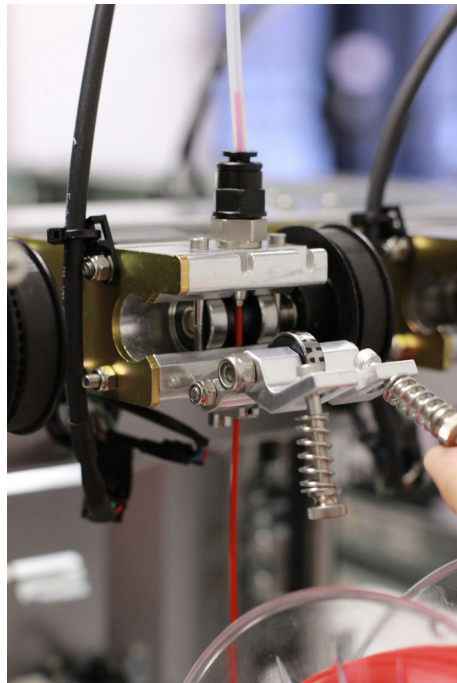

Step 3. Extrude filament by hand (optional). If your hot end has reached the recommended temperature for your filament you will be able to push the filament through the guide tube until extrudes out the nozzle tip. This is a quick and easy way to prime your hot end with filament.

Step 4. Secure the idler bearing assembly, as shown. You will use manual control to prime the hot end in the following steps.

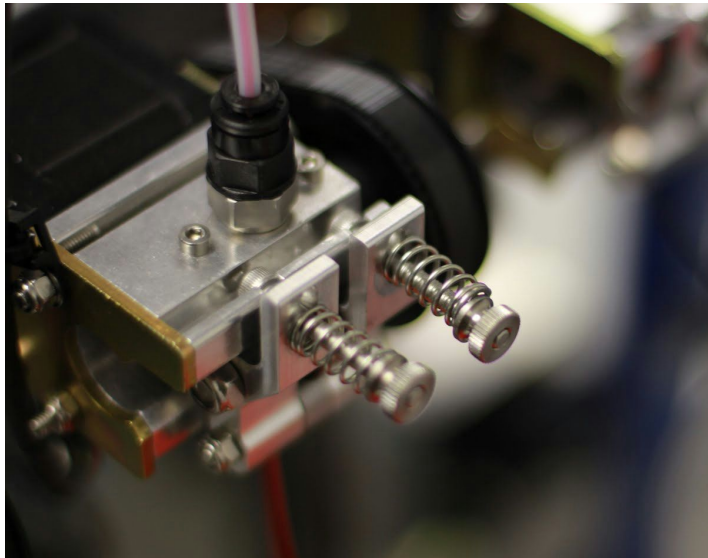

5.6. Manual control via STACKER RUN

1. Overview of controls.

The manual control panel in STACKER RUN allows you to make incremental movements and home the X, Y, and Z axes, manually extrude or retract filament, turn on extruders, fans, and the heat bed. You can also manually adjust temperatures for the heat bed and extruders. Learn more about the manual control panel on the Repetier website:

- <http://www.repetier.com/documentation/repetier-host/rhmanual-control/>

2. Sending gcode to the printer.

From the manual control panel, STACKER can accept most gcode commands. For advanced users this can be quite helpful. You can also send special gcode commands to engage ditto mode printing for making multiple copies of the same file. Here is a list of most codes that are compatible with STACKER.

Implemented Codes

- G0 -> G1
- G1 - Coordinated Movement X Y Z E
- G4 - Dwell S or P
- G20 - Units for G0/G1 are inches.
- G21 - Units for G0/G1 are mm.
- G28 - Home all axis or named axis.

- G90 - Use absolute coordinates
- G91 - Use relative coordinates
- G92 - Set current position to coordinates given

RepRap M Codes

- M104 S[target temperature] - Set extruder target temp
- M105 - Read current temp
- M106 S[Speed 0..255] - Fan on
- M107 - Fan off
- M109 - Wait for extruder current temp to reach target temp.
- M112 - Emergency stop.
- M114 - Display current position

Custom M Codes

- M80 - Turn on Power Supply
- M20 - List SD card
- M21 - Init SD card
- M22 - Release SD card
- M23 - Select SD file (M23 filename.g)
- M24 - Start/resume SD print
- M25 - Pause SD print
- M26 - Set SD position in bytes (M26 S12345)
- M27 - Report SD print status
- M28 - Start SD write (M28 filename.g)
- M29 - Stop SD write
- M80 - Turn on power supply
- M81 - Turn off power supply
- M82 - Set E codes absolute (default)
- M83 - Set E codes relative while in Absolute Coordinates (G90) mode
- M84 - Disable steppers until next move, or use S to specify an inactivity timeout, after which the steppers will be disabled. S0 to disable the timeout.
- M85 - Set inactivity shutdown timer with parameter S. To disable set zero (default)
- M92 - Set axis_steps_per_unit - same syntax as G92
- M115 - Capabilities string
- M140 S[TargetTemperature] - Set bed target temp
- M190 - Wait for bed current temp to reach target temp.
- M201 - Set max acceleration in units/s² for print moves (M201 X1000 Y1000)
- M202 - Set max acceleration in units/s² for travel moves (M202 X1000 Y1000)

- M203 - Set temperature monitor to Sx
- M204 X[Kp] Y[Ki] Z[Kd] - Set PID parameter. Values are 100*real value!
- M205 - Output EEPROM settings
- M206 - Set EEPROM value
- M231 S[OPS_MODE] X[Min_Distance] Y[Retract] Z[Backslash] F[RetractMove] - Set OPS parameter
- M232 - Read and reset max. advance values
- M280 S0 - Print single head only (cancels ditto mode for more than one head)
- M280 S1 - Ditto print mode for heads 1 and 2 (for making two copies at same time)
- M280 S2 - Ditto print mode for heads 1, 2 and 3 (for making three copies at same time)
- M280 S3 - Ditto print mode for heads 1, 2, 3 and 4 (for making four copies at same time)

5.7. SD Card Printing

We recommend printing directly from the SD card because the connection is more reliable than a USB connection. For example, if your computer shuts down or hibernates it can result in a failed print. You may want to change your computer's settings so that it does not go to sleep during a print. When in doubt, load your gcode onto the supplied SD card and insert it into the controller, or preferably the LCD Smart Controller (optional).

For your first prints, you can download a Test Print gcode file from our website:

- <http://stacker3d.com/kickstarter-support>

If your computer does not have an SD card slot, you can purchase an inexpensive pocket sized SD card reader that will work with an available USB port on your computer.



Once the files are copied to your microSD card, remove the card from your computer and insert the card into the microSD slot is located on Controller Housing on the back of your printer beneath the USB cable input. When inserting a microSD card, be very careful to avoid dropping the card into the Controller Housing!

MicroSD Card Slot
(Below USB Port)

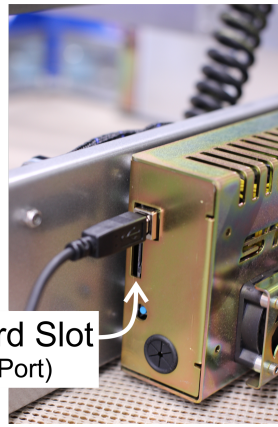

You will be able to access the files on the microSD card through STACKER RUN software by clicking on the SD Card tab. From the file list, select the file you wish to print.

Save files to SD card from Cura or Slic3r.

Be sure to select “Save in Binary Format”. Also, make sure your SD card is inserted into your computer, not the controller or LCD smart controller. After the file is saved, now you can move it to your printer’s controller. If you use a third party slicer, like Simplify3D, use the same method of saving to SD on your computer, and then transferring it to your printer’s controller.

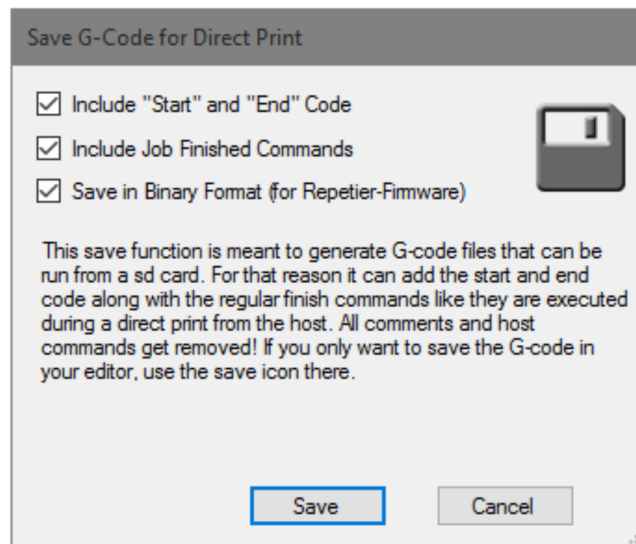

5.8. First Print

First Layer Height.

It is really important to get the first layer height spot on. If your first layer is too high the filament will not adhere properly to your print bed. If the your first layer is too low the filament will not be able to come out of the nozzle and this will result in the filament drive stripping out filament.

You can manually adjust the layer height by turning the fine adjustment knob on the end of the z-probe. Turning the knob clockwise will LOWER the bed upon rehomeing the Z-axis (increasing layer height). Turning the knob counter clockwise will RAISE the bed into the nozzles upon

rehomeing the Z-axis (decreasing layer height). Each full rotation will adjust the layer height by 0.75mm.

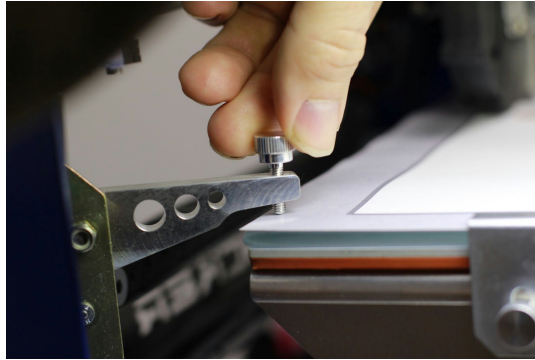

It's much better to start your first print with a higher first layer height to prevent your bed from contacting the nozzles. Simply readjust and rehome the bed until the first layer height is spot on. Use test prints to help you accomplish this. Be sure your bed is level before you begin.

If your print quality is less than desired, please take a look at the Simplify3D print quality troubleshooting guide. It provides excellent visuals of common problems and solutions.

- <https://www.simplify3d.com/support/print-quality-troubleshooting/>

5.9. Multi-part Print Mode

With STACKER's multi-part print mode, each extruder can print a copy of the same object. You can print up to four copies in the same time it would take to print one! With multi-part printing, you can print 2, 3, or 4 COPIES at once.

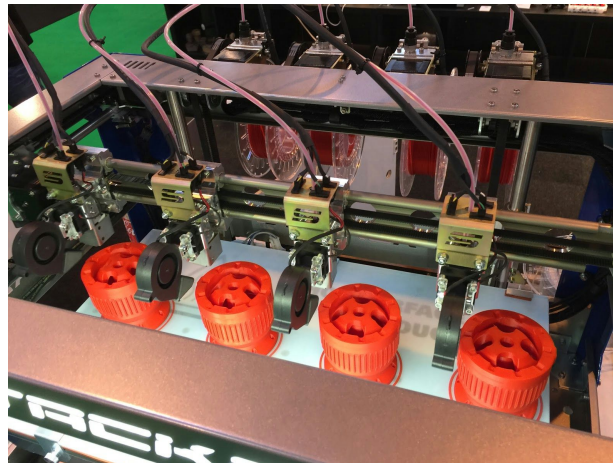

Set Extrusion Mode

In order to print multiple copies of the same object, you need to turn on multi-part print mode by clicking on the "Extruder Setup" button. Be absolutely sure all hot ends are turned off before you

change the extruder setup.

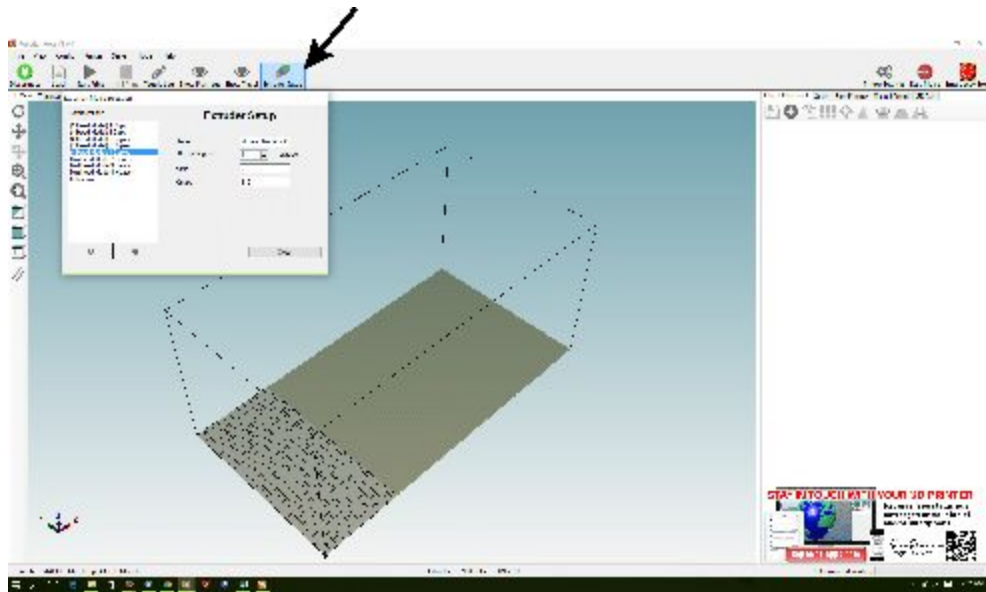

The Extruder Setup button will open the Extrusion Mode Selection window where you can select the number of copies you wish to print. Click on the desired number of copies and close the window.

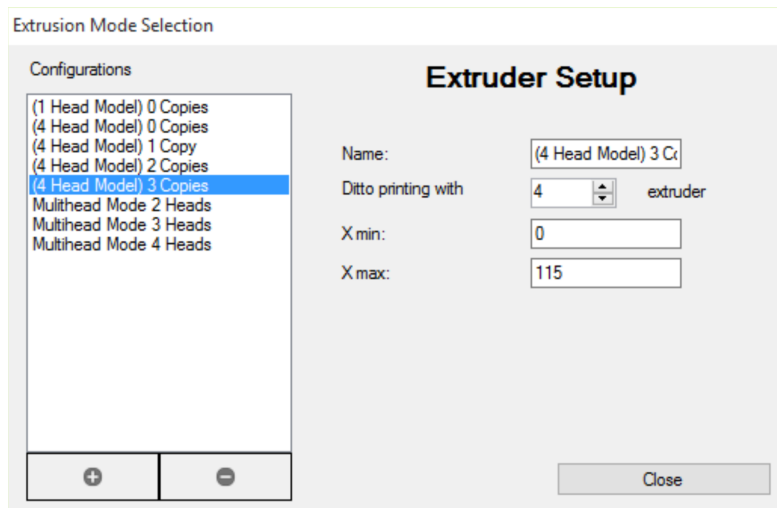

Take note that the build area in the graphic of the bed changes size depending upon the number of print heads being used. When you place your object for printing, it must fit within the available area shown. In the image below, the object has been placed within the available print bed area.

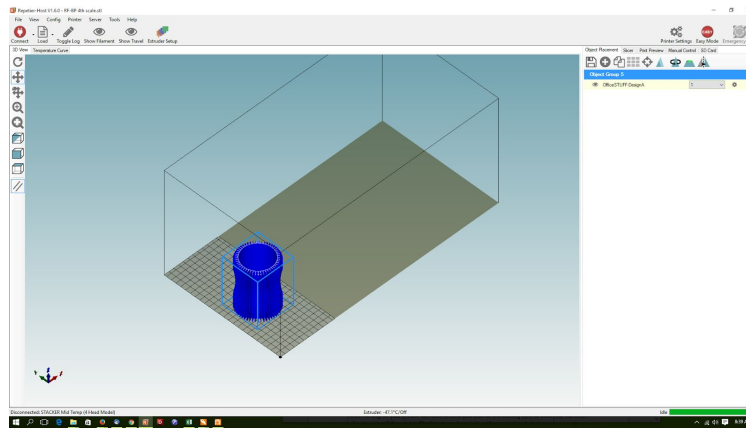

Spacing the Heads

In multihead print mode, each of your heads will operate on only a portion of the print bed, so you will need to space your print heads apart at specific distances along the X gantry depending upon the number of print heads you are using.

Number of Copies	Spacing Between Heads
2	189mm
3	140mm
4	115mm

To determine the placement of each head along the X gantry, you can use a tape measure and set the distance between heads. In the image below, the head are set for 4 head printing, so they are separated by 115mm (as shown).

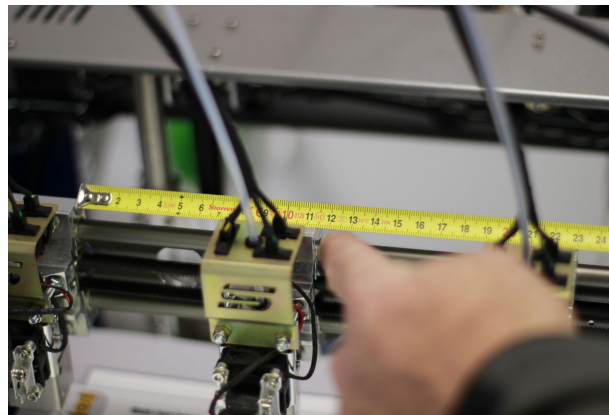

To easily setup your print heads for multihead printing, we recommend using our 3D Printer BuildTak (p/n 90-105) available on our website. Our BuildTak comes with a custom spacing template to easily place your print heads in the correct location. We have also placed a printable template on our website at <http://stacker3d.com/kickstarter-support> to assist you in head placement, but please be aware that each printer can scale the print differently, so please always refer to the distances between heads as your guide.

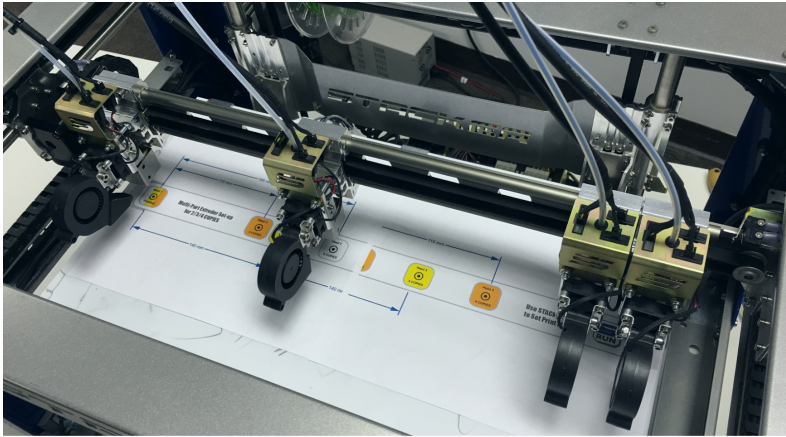
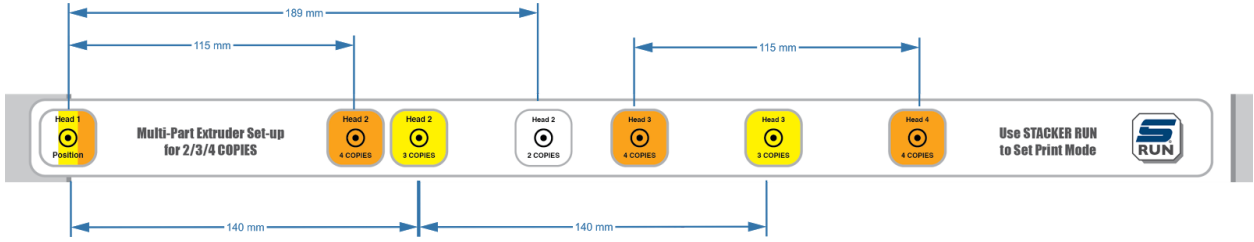

In the image above, the template has been placed upon the print bed, and the head have been placed for two head printing. Head 1 is directly over the “Head 1” position, and the second head is placed directly over the “Head 2 -- 2 Copies” position. The two unused heads are moved to the far right side of the gantry. Note, if the unused heads are pushed too far to the right, they will trip the X-Max End Stop

Incorrect

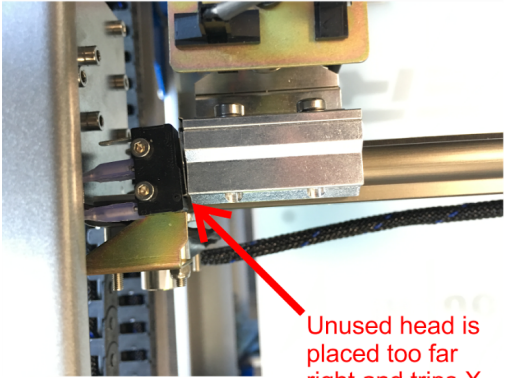

Unused head is placed too far right and trips X-Max End Stop

Correct

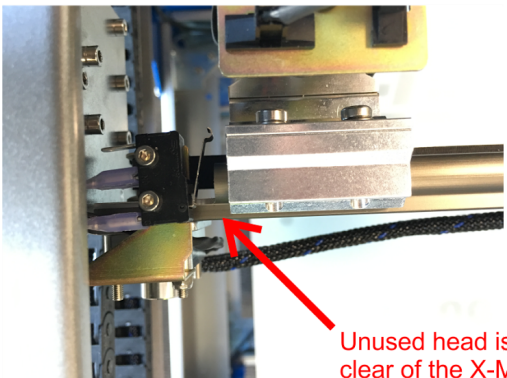

Unused head is clear of the X-Max End Stop

When each print head has been moved to its location along the X gantry, you must secure each of these heads to your belt. To do this, attach the belt block from the rear of the X gantry. Push the belt block upward with a screwdriver and tighten the two screws with the 2.5mm wrench. You may need to shift the heads left or right to gain access through the port hole.

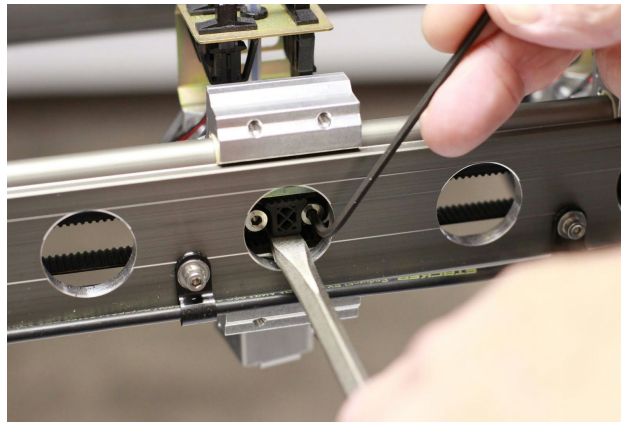

When your heads are positioned and secured to belt, you are ready for multihead printing.

5.10. Multi-material Print Mode

For multi-material printing, STACKER recommends purchasing Simplify3D and following their tutorials. <https://www.simplify3d.com/>

5.11. Slicing Engines

Slicing engines are used to convert an stl file of into gcode which operates the printer. The gcode provides the commands for the printer to print your 3D object. STACKER RUN includes two open source slicing engines (Slic3r and Cura), and both of these slicing engines do a good job. Nevertheless, we highly recommends purchasing Simplify3D. We have found Simplify3D to be one of the best slicing engines on the market.

The links below can help familiarize you with the operation of a slicing engine.



- <http://manual.slic3r.org/intro/overview>



- <https://www.simplify3d.com/support/>

6. Turning Off your Printer



When turning off your printer, we recommend you **wait for the cooling fans to fully cool your extruders before turning off the printer**. You can observe the temperatures of your extruders on the Manual Control tab of STACKER RUN. Shutting down the printer with hot extruders can damage your hot ends. Proper cooling is necessary to prolong the life of your hot ends.

7. Volumetric Calibration

The secret to accurate prints and beautiful surface finish is proper volumetric flow control. We control volume with four variables: (1) filament diameter, (2) nozzle size, (3) filament drive E-STEPS, and (4) extrusion multiplier. The slicing engines use these variables to determine exactly how much filament to extrude. Therefore, it's essential to set these variables carefully and accurately.

(1) Filament Diameter: It's very important to only use filament with highly consistent filament diameters. That is why STACKER has partnered with ColorFabb to manufacture our filaments. ColorFabb uses highly advanced laser tools for precise diametric measurements, as well as a host of other controls to ensure consistent filament diameters. Regardless of what filament brand you use, start with a digital caliper and measure the diameter of your filament in few different places to see if it is consistent. If the diameter is inconsistent, return the filament to where you purchased it.

Once you have established the consistency of your filament diameter, be sure to insert the measured value into your slicer settings.

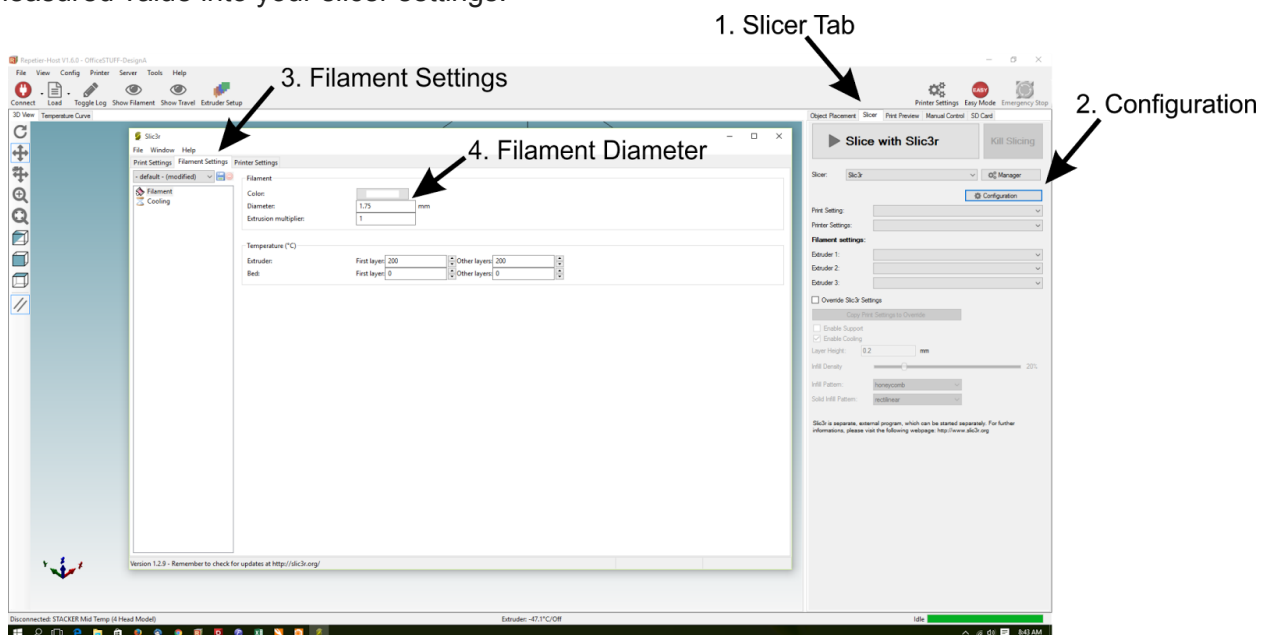

1. Click on the Slicer Tab
2. Click on the Configuration to open the Slicer window
3. Select the Filament Settings tab
4. Enter your Filament Diameter

(2) Nozzle Size: STACKER nozzles use a system of small machined dots around the tip for identification purposes. You need to make sure you are entering the proper nozzle size in your slicing engine, as well as, the printer configuration in STACKER RUN. STACKER's standard nozzle size is 0.5mm, also called a 050 nozzle.

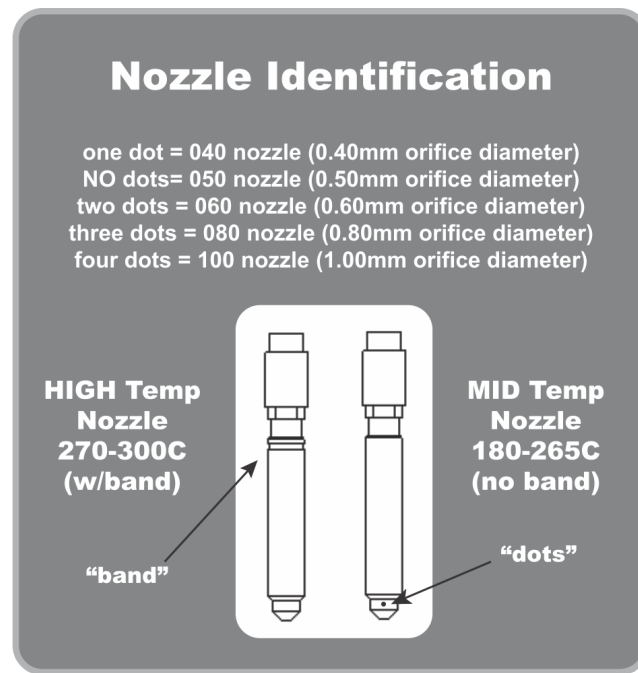

MID and HIGH temp nozzles.

For most filaments, you will use our MID temp nozzles. This includes: PLA, ABS, Copolyester, HIPS, and special filaments like carbon fiber XT-CF20, BambooFill, and BronzeFill.

With certain filaments that require temperatures between 270° and 300°C we recommend using our HIGH TEMP nozzles. The HIGH TEMP nozzles have a special machined “band” to distinguish them from our MID temp nozzles. Again, for most filaments, we recommend using the MID temp nozzles.

Using the graphic above to identify your nozzle, and then, within the slicing engine, you will enter your nozzle size.

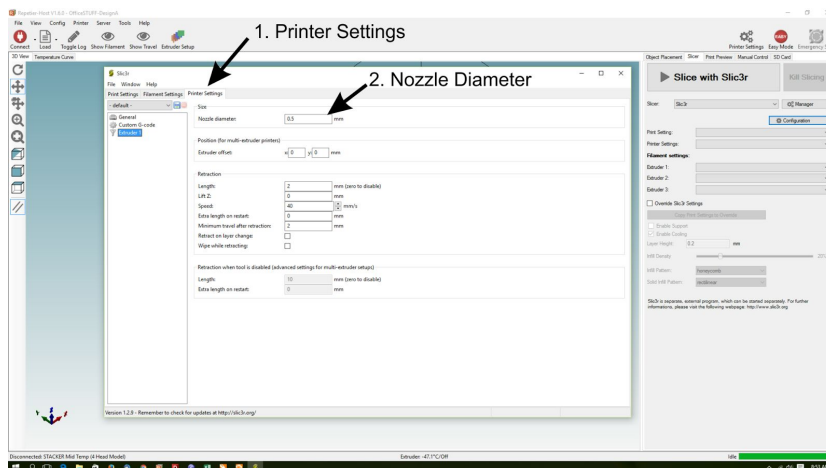

1. Click on the Printer Settings tab
2. Enter your Nozzle Diameter

(3) Filament Drive E-STEPS: Calibrating your filament drive E-STEPS (also called extruder steps) is essential, and should be done every time you change filament types or brands. Your E-STEPS number tells your controller how many times it should pulse the stepper motor on the filament drive. For example, if you use the manual control tab to extrude 100mm of filament, and the E-STEPS is correct, your filament drive will extrude exactly 100mm.

The calibration process only takes a minute and doesn't require you to waste filament. All you need is a metric ruler, a calculator, and an ink pen. Please follow these steps.

A) Heat up your hot end, and leave it on; this will allow you to manually extrude. Release the filament drive idler bearing assembly and manually pull back approximately 300mm of filament. You could retract the filament using the Manual Control tab, but it is much quicker to pull the filament by hand. Finally, re-attach the idler bearing assembly on the filament drive. You are now ready for the next step.

B) Use a ruler and pen mark off 120mm on the filament, as shown in the photo below.

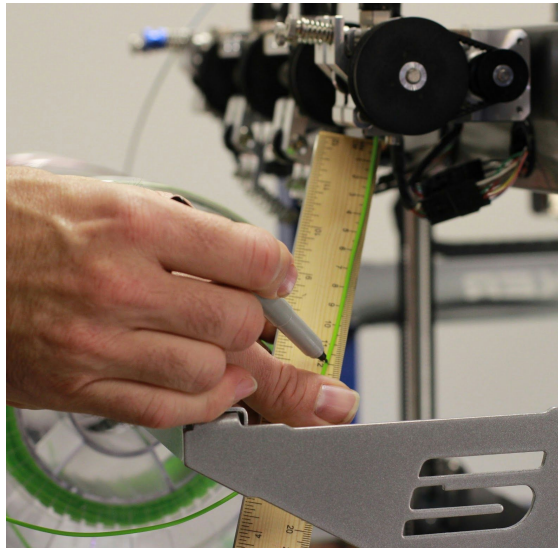

C) Using the Manual Control tab, extrude exactly 120mm of filament. Then, measure what was actually extruded and write down the number. You will use it in the next step. In my test (seen in the image below), I attempted to extrude 120mm of filament, but the printer only extruded 115mm.

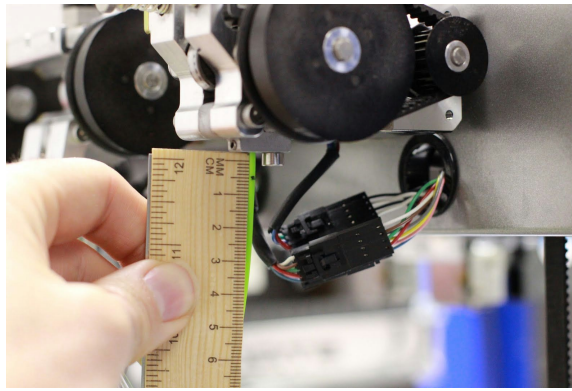

D) Open your EEPROM window in STACKER RUN by pressing Alt+E or select “Firmware EEPROM Configuration” under the Config menu to see your current E-STEPS for each extruder.

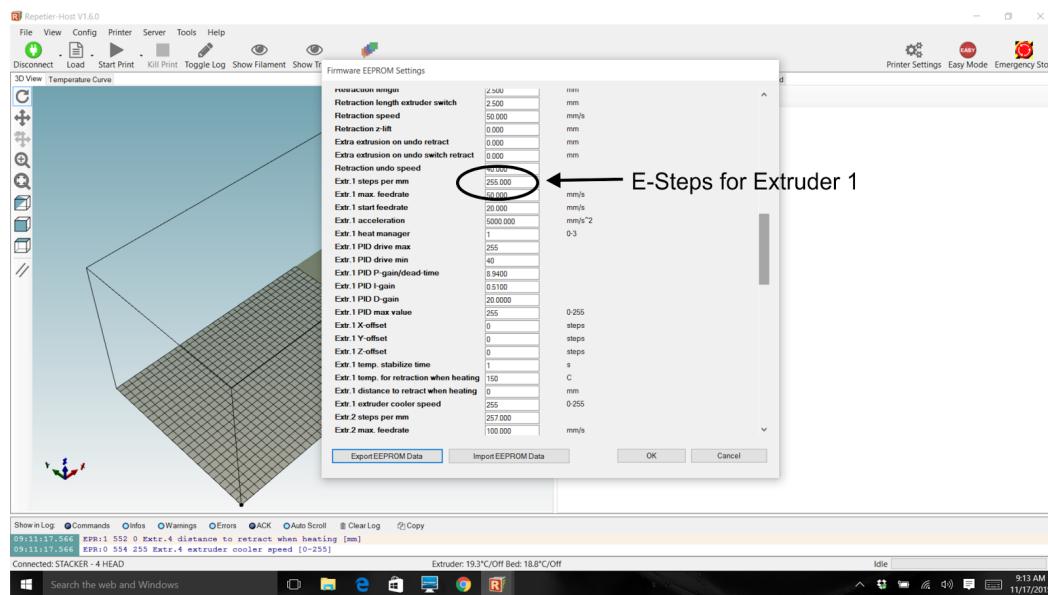

To calculate the new E-STEPS number, use this formula:

$$(120\text{mm} \div \text{Your Measurement}) \times (\text{Your current E-Steps}) = \text{Your New E-Steps}$$

For example, I attempted to extrude 120mm of filament, but the printer only extruded 115mm of filament.

$$120 \div 115 = 1.043478$$

If your current "steps per mm" in the EEPROM is set to 255:

$$1.043478 \times 255 = 266.09$$

Thus, in this example, I should change the "steps per mm" from 255 to 266.09 with this filament.

E) Enter your new E-Steps for your extruder. It is now time to test your result. Go back and repeat steps 2 through 5 again to confirm your result.

(4) Extrusion Multiplier

For even finer volumetric calibration you can adjust the extrusion multiplier in your slicing engine. Most filaments will print VERY accurately with a 100% extrusion multiplier setting in your slicing engine. However, some filaments like XT-CF20 Carbon Fiber filament will over extrude due to die swell, and will therefore require a lower extrusion multiplier, perhaps as low as .88. Printing a simple single wall test cube will allow you to see exactly how accurate your print widths are. There are many of these types of calibration models available on the internet. As you gain experience in 3D printing you will accomplish accurate results quite easily. Using the same filament will also help you maintain consistency.

8. Calibration of X/Y/Z Motion System.

Your new STACKER 3D printer is fully calibrated at the factory. However, the shipping process can throw off tolerances and so too can environmental conditions like hot and cold temperatures, heavy humidity, etc. Also, as your 3D printer goes through the break-in process things like belt and bearing tension may require slight adjustments from time to time.

There are four basic calibration/adjustment areas associated with your X/Y/Z Motion System:

1. **Bearing Clearance/Fit**
2. **Belt Tension**
3. **X/Y Gantry Squareness**
4. **X/Y/Z Motor Steps/MM**

Please take each one of these calibration steps in order. For example, it's important to get your gantry square and belts tensioned properly BEFORE you change the motor steps in your EEPROM, as changes to either of these two things will have an obvious impact on your step settings.

Step 1. Bearing Clearance/Fit.

To adjust the bearing clearance on the Y and Z axis, use a 2.5mm hex wrench, as shown. Be VERY careful not to overtighten the bearings. If your bearings are too tight, simply loosen these screws. Only do this step if you can feel a lot of slop.



To adjust the bearing clearance on the print heads (X axis), begin by removing the hot end heater block with the 1.5mm hex wrench. Then, loosen these two screws, as shown in the photo below.

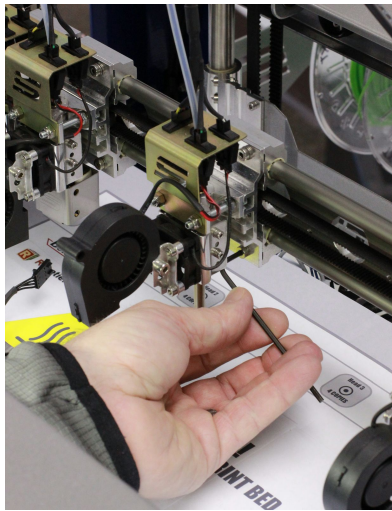

Next, use one hand to squeeze the bearing blocks together while tightening the two lower screws with your other hand. Don't squeeze too tightly. You want the heads to slide effortlessly.

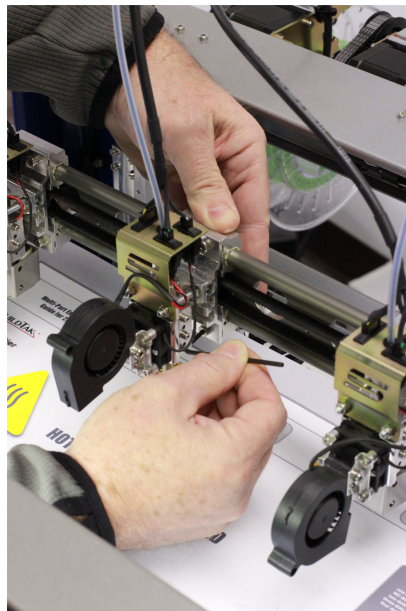

Squeeze head and tighten lower bolts.

Step 2. Belt Tension.

The belts should be properly tensioned and stay this way for many hours of use. In case the belts do come loose or the tension changes, simply tighten the thumb nuts by hand, or use a 7mm wrench for the x-gantry.

When tightening the tension on the Y or Z axis, its absolutely important that you tighten BOTH thumb nuts equally. This does not, of course, apply to the X axis, as here you only have one adjustment point. See the photos below.

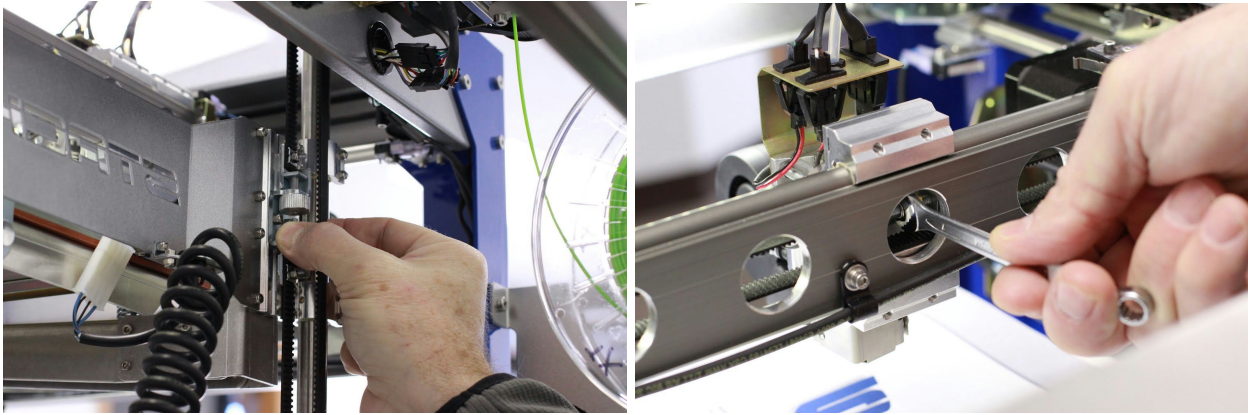

Step 3. X/Y Gantry Squareness

The gantry should remain square from the factory unless the Y Axis belt tension has been altered unevenly. Keep in mind, there are TWO Y Axis belts connected by a common shaft. Therefore, the easiest way to square up the gantry is by adjusting the belts. The purpose of adjusting the belts is to move the Left side Y Axis bearing/belt tension bracket in one direction, and the Right side Y Axis bearing/belt tension bracket in the opposite direction, until the X gantry is square to the Y Axis.

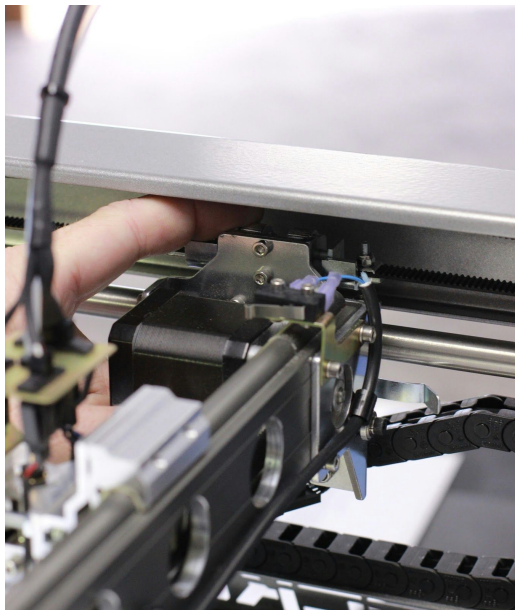

You can either use a test print to validate the squareness of your gantry or get out a series of precision squares and spacers to accomplish the task directly. It's actually a lot easier to test by simply printing a square test object.

Adjustment procedure.

First off, work with one bearing/belt tension bracket at a time. To move the bracket simply loosen the thumb nut on the opposite side you want the bracket to move. Then tighten the thumb nut on

the side you want the gantry to move. Be sure each move of the thumb nuts is equal distance, say $\frac{1}{8}$ of a turn.

Next, go to the other bearing/belt tension bracket and move it the opposite direction using the same procedure.

Be sure to retest the squareness by printing another test object. Once your print is complete, remove from the print bed and throw a square on it to confirm. Remember the orientation of the part on the print bed so you know which way to move the tension blocks.

Step 4. X/Y/Z Motor Steps/MM and Z-axis Backlash settings

The easiest way to adjust the X/Y/Z steps is to purchase the following dial indicator and holder. This one can be purchased from Amazon for less than 100 dollars. Much less expensive non digital indicator versions sell for around 30 dollars or less. This type of test equipment is a good value. In the photos below you can see how we positioned the indicator. There are many ways to position the indicator, so use our photos as only a guide.



X Axis Calibration Setup

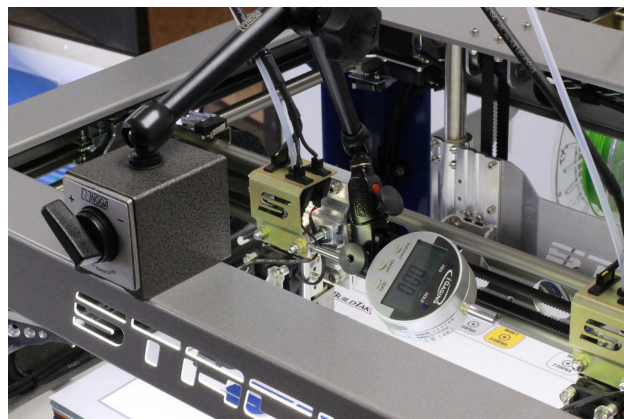

Y Axis Calibration Setup

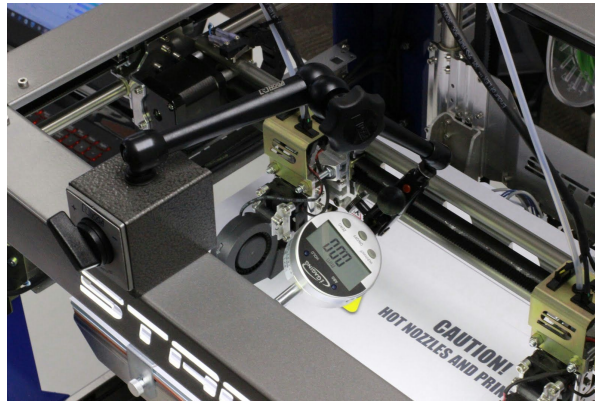

Z Axis Calibration Setup for Steps/MM and Z Axis Backlash



Change your steps in the EEPROM.

Now you need to open your EEPROM window in STACKER RUN by pressing Alt+E or select "Firmware EEPROM Configuration" under the Config menu.

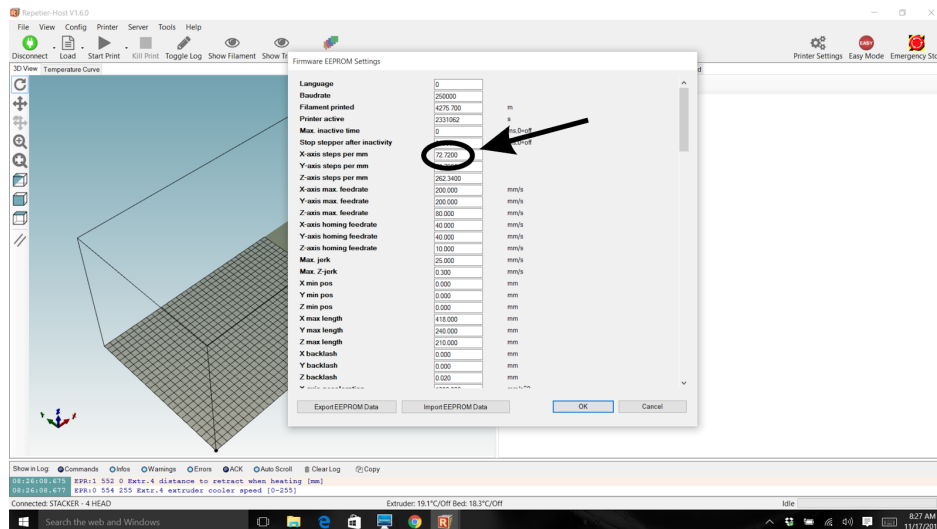

To calculate the new motor steps, use this formula below:

(The distance you want to move ÷ Measured distance) x (Your current motor steps) = Your new motor steps NUMBER

For example, I attempted to move the print heads (X axis) 10mm, but the printer only moved 9.5mm.

$$100 \div 9.5 = 1.05263$$

If this case the current "X axis steps per mm" in the EEPROM is set to 72.72. Therefore:

$$1.05263 \times 72.72 = 76.54$$

Thus, in this example, I should change the "X axis steps per mm" from 72.72 to 76.54.

Now, use the manual control to move the gantry 10mm. Write down the number measured. Make the calculation and update the EEPROM with the new step number.

Repeat the process for the Y and Z axis, if needed.

Z-Axis Backlash Calibration Procedure.

1. Open the EEPROM and change the Z backlash number to 0mm.
2. Home the Z-Axis
3. Set up dial indicator and zero out.
4. Send the print bed down 1mm using STACKER RUN
5. Measure the actual distance traveled using the dial indicator.

6. Subtract the distance traveled from 1mm. This is the number you put into the EEPROM
7. Retest with new backlash number to verify.

8.1. Vref for Stepper Motor Drivers

The information provided this section is primarily for reference. The Vref (voltage reference) for the stepper motor drivers was set at the factory. It is unlikely that you would ever be required to adjust these settings.

If you decided to test or adjust your Vref settings be certain to discharge any static electricity before touching any of the electronic components on your printer. **DO NOT MAKE ADJUSTMENTS WHILE THE MOTORS ARE OPERATING**, and when making adjustments, **NEVER EXCEED YOUR MOTOR'S CURRENT RATING**. Obviously, you will need to have your printer turned on and the controller housing cover removed. It is extremely important that you do not run the motors prior to adjusting the Vref. Also, exceeding the motor's current rating can damage both the motor and the stepper motor driver.

To check the Vref settings do the following:

1. Remove the controller cover, detach the fan wires, and set it aside.
2. Turn on the printer. Do not touch the LCD smart controller or connect via any host software, such as STACKER RUN.
3. Using a very high quality voltage meter touch the + of the voltmeter to the VREF Test Point on the driver and the [-] lead to the Ground Nut. **BE EXTREMELY CAREFUL!** You run the risk of shorting out all sorts of things with your voltmeter and small screw driver. You must proceed carefully and with steady hands.

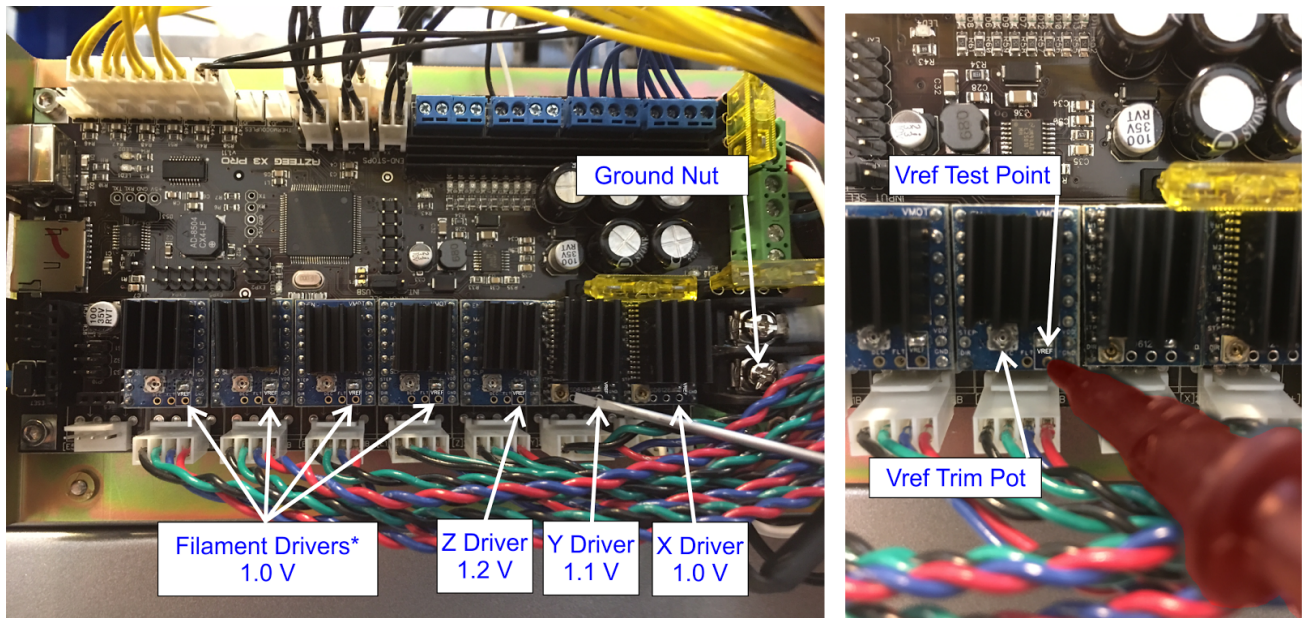

*Note, the 2 head model will only have 2 filament drivers.

The factory voltage values are noted on the image above. The current limit can be adjusted by turning the Vref Trim Pot with a small slot head screwdriver. Turning clockwise will increase voltage. Turning counterclockwise will reduce voltage. **DO NOT EXCEED THE FACTORY VOLTAGES!**

More information about the stepper motor drivers can be found at:

http://files.panucatt.com/datasheets/sd8825_user_guide.pdf

http://files.panucatt.com/datasheets/sd6128_user_guide.pdf

9. Useful Information

9.1. Power Supply Data Sheet



600W Single Output with PFC Function

HRP-600 series



■ Features :

- Universal AC input / Full range
- Built-in active PFC function, PF>0.94
- High efficiency up to 89%
- Withstand 300VAC surge input for 5 seconds
- Protections: Short circuit / Overload / Over voltage / Over temperature
- Built-in constant current limiting circuit
- Built-in cooling fan ON-OFF control
- Built-in DC OK signal
- Built-in remote sense function
- All using 105°C long life electrolytic capacitors
- 5 years warranty



SPECIFICATION

MODEL		HRP-600-24							
OUTPUT	DC VOLTAGE	24V							
	RATED CURRENT	27A							
	CURRENT RANGE	0 ~ 27A							
	RATED POWER	648W							
	RIPPLE & NOISE (max.) Note.2	150mVp-p							
	VOLTAGE ADJ. RANGE	21.6 ~ 28.8V							
	VOLTAGE TOLERANCE Note.3	±1.0%							
	LINE REGULATION	±0.2%							
	LOAD REGULATION	±0.5%							
SETUP, RISE TIME	1000ms, 50ms/230VAC		2500ms, 50ms/115VAC at full load						
HOLD UP TIME (Typ.)	16ms/230VAC		16ms/115VAC at full load						
INPUT	VOLTAGE RANGE Note.5	85 ~ 264VAC		120 ~ 370VDC					
	FREQUENCY RANGE	47 ~ 63Hz							
	POWER FACTOR (Typ.)	PF>0.94/230VAC		PF>0.99/115VAC at full load					
	EFFICIENCY (Typ.)	78.5%	82%	87%	88%	88%	88%	89%	89%
	AC CURRENT (Typ.)	7.6A/115VAC		3.6A/230VAC					
	INRUSH CURRENT (Typ.)	35A/115VAC		70A/230VAC					
	LEAKAGE CURRENT	<1.2mA / 240VAC							
PROTECTION	OVERLOAD	105 ~ 135% rated output power Protection type : Constant current limiting, recovers automatically after fault condition is removed							
	OVER VOLTAGE	3.96 ~ 4.62V	6 ~ 7V	9.4 ~ 10.9V	14.4 ~ 16.8V	18.8 ~ 21.8V	30 ~ 34.8V	41.4 ~ 48.6V	57.6 ~ 67.2V
	OVER TEMPERATURE	Shut down o/p voltage, recovers automatically after temperature goes down							
FUNCTION	DC OK SIGNAL	PSU turn on : 3.3 ~ 5.6V ; PSU turn off : 0 ~ 1V							
	FAN CONTROL (Typ.)	Load 35±15% or RTH2≥50°C Fan on							
ENVIRONMENT	WORKING TEMP.	-40 ~ +70°C (Refer to "Derating Curve")							
	WORKING HUMIDITY	20 ~ 90% RH non-condensing							
	STORAGE TEMP., HUMIDITY	-40 ~ +85°C, 10 ~ 95% RH							
	TEMP. COEFFICIENT	±0.03%/°C (0 ~ 50°C)							
SAFETY & EMC (Note 4)	VIBRATION	10 ~ 500Hz, 5G 10min./1cycle, 60min. each along X, Y, Z axes							
	SAFETY STANDARDS	UL60950-1, TUV EN60950-1 approved							
	WITHSTAND VOLTAGE	I/P-O/P:3KVAC		I/P-FG:2KVAC		O/P-FG:0.5KVAC			
	ISOLATION RESISTANCE	I/P-O/P, I/P-FG, O/P-FG:100M Ohms / 500VDC / 25°C / 70% RH							
	EMC EMISSION	Compliance to EN55022 (CISPR22) Class B, EN61000-3-2,-3							
OTHERS	EMC IMMUNITY	Compliance to EN61000-4-2,3,4,5,6,8,11, EN55024, EN61000-6-2, heavy industry level, criteria A							
	MTBF	140.6K hrs min. MIL-HDBK-217F (25°C)							
	DIMENSION	218*105*63.5mm (L*W*H)							
NOTE	PACKING	1.5Kg,8pcs/13Kg/1.34CUFT							
	<p>1. All parameters NOT specially mentioned are measured at 230VAC input, rated load and 25°C of ambient temperature. 2. Ripple & noise are measured at 20MHz of bandwidth by using a 12" twisted pair-wire terminated with a 0.1uf & 47uf parallel capacitor. 3. Tolerance : includes set up tolerance, line regulation and load regulation. 4. The power supply is considered a component which will be installed into a final equipment. All the EMC tests are been executed by mounting the unit on a 360mm*360mm metal plate with 1mm of thickness. The final equipment must be re-confirmed that it still meets EMC directives. For guidance on how to perform these EMC tests, please refer to "EMI testing of component power supplies." (as available on http://www.meanwell.com) 5. Derating may be needed under low input voltages. Please check the derating curve for more details.</p>								

9.2 Installing the LCD Smart Controller (Option Sold Separately)

The LCD Smart Controller (p/n 90-103) allows you to operate your printer without the need for a PC or laptop. It is available from our website <http://www.stacker3d.com>.

Before installing the LCD Smart Controller option, you must be certain that your printer has been turned off and the power cord is disconnected.



STATIC DISCHARGE WARNING! Ground yourself before touching the printer or any of the printer's electronic components. Discharge your static before touching your printer!

Step 1. Remove the electronics controller housing cover

Use a 2mm hex key to remove the four screws and detach the controller housing cover. When removing the cover, be careful to avoid damaging the wires of the three cooling fans. Detach the small wire connectors to the fans, then place the controller housing cover aside for now.



Step 2. Remove the cable bushing from controller housing

Use your finger to pop out the bushing by pressing from the inside of the controller housing (as shown). You may also need to press down on the little tab.

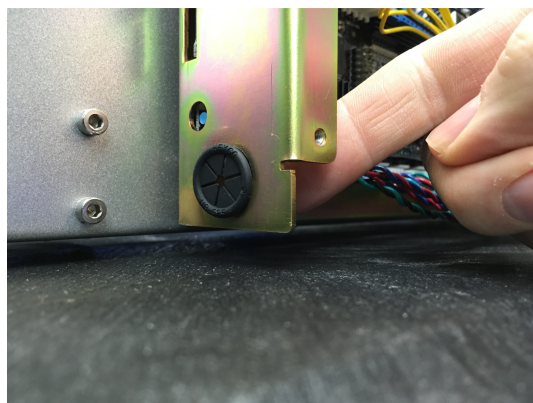

Step 3. Insert the loose wires through the bushing

Begin this step by pre-bending the tabs of the little plastic bushing inward, as this will make it easier to push the individual wires through the bushing. Use a small 5.5mm socket or similar sized object to pre-bend the tabs. Only push about 3 or 4 wires through at a time!



This is how it will look when you are done pushing all the wires through the bushing. The distance from the end of the wires to the bushings should be about 5" or 13cm.

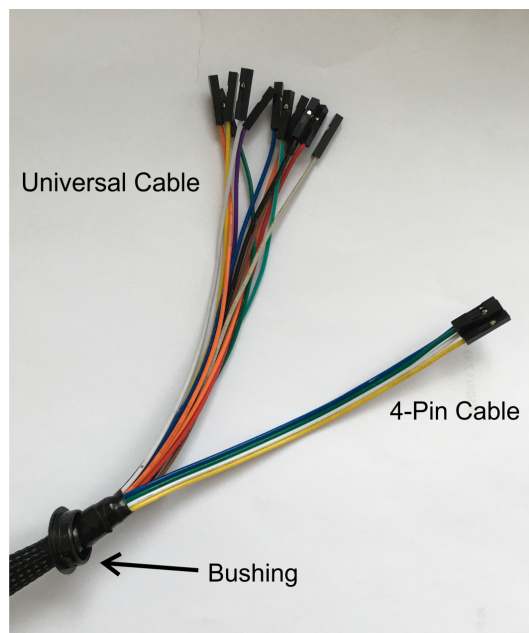

Step 4. Install the wires harness and snap the bushing back into the controller housing

Push the wires through the hole in the controller housing; be careful of sharp edges! Once all the wires have been pushed through the hole, snap the bushing to the controller housing by pressing it with your finger. See photos below.

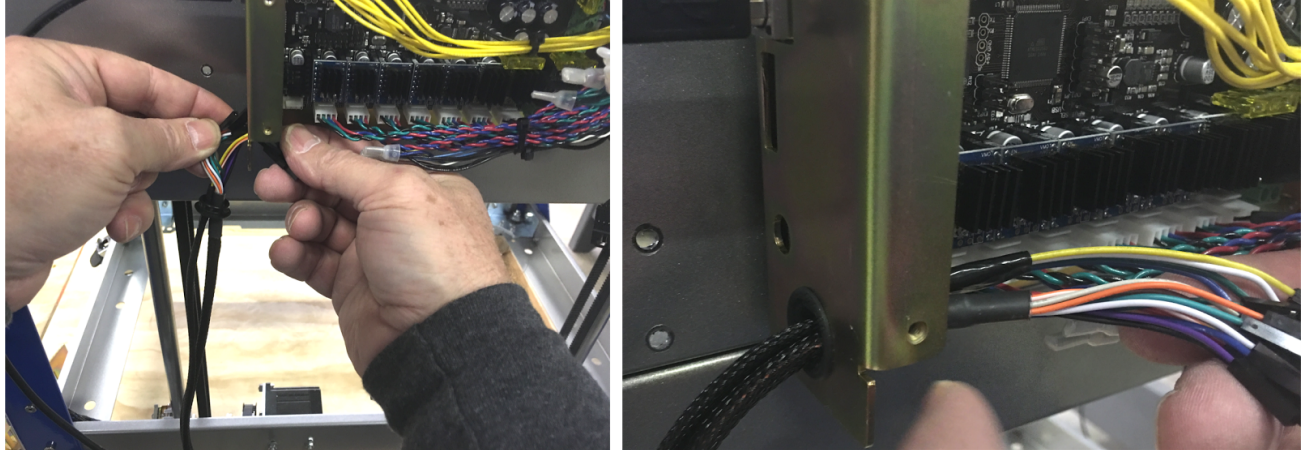
**Step 5. Attach the Wires to the Controller Board**

The wires are separated into two groups: the universal cable with 12 wires and the 4-pin cable with 4 wires. Because both groups of wires share a blue, green, white, and yellow wire jacket color, it is important to distinguish between these two groups to avoid attaching a wire to the wrong pin. Note, the wires of the 4-pin cable have been labeled and are loosely attached to each other.

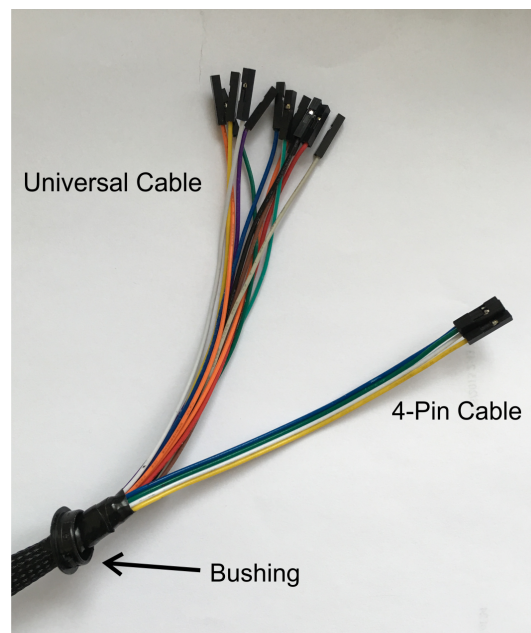

Using the graphic below, the color of each wire is used to determine its pin location on the controller board. The four 4-Pin Wire locations are circular in shape highlighted by arrows. Also note, you may have to remove a jumper to attach the purple wire.

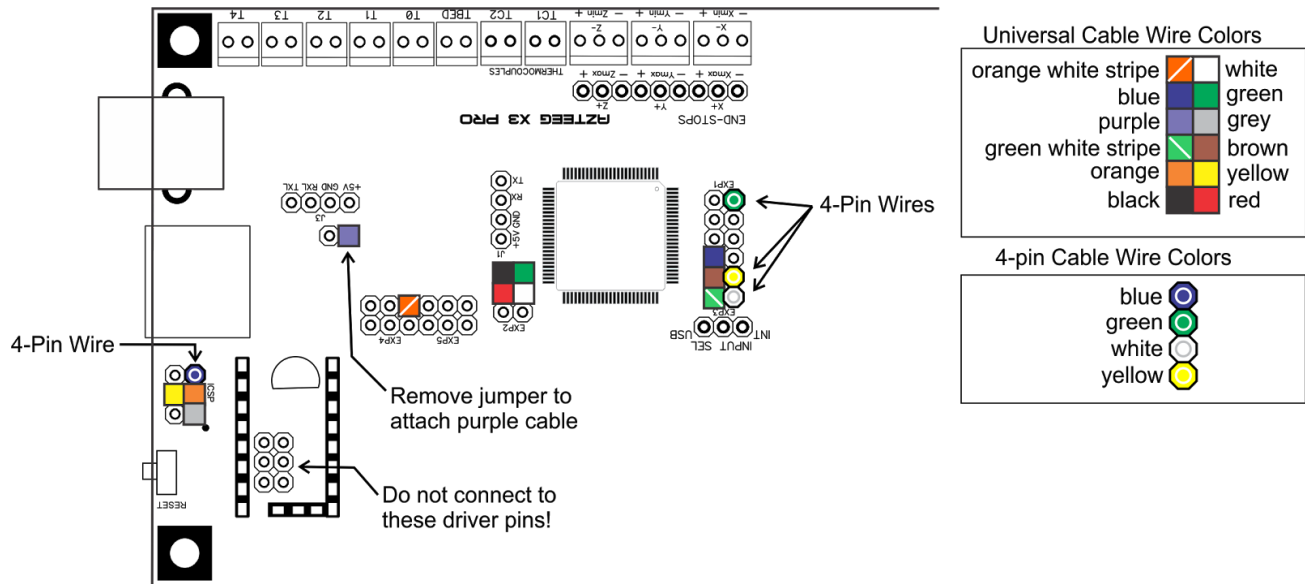

To begin attaching the wires to the controller, we recommend using a pliers and starting on the far left side with the yellow wire from the universal cable. It is best to take care of these wires first, because they are most challenging.

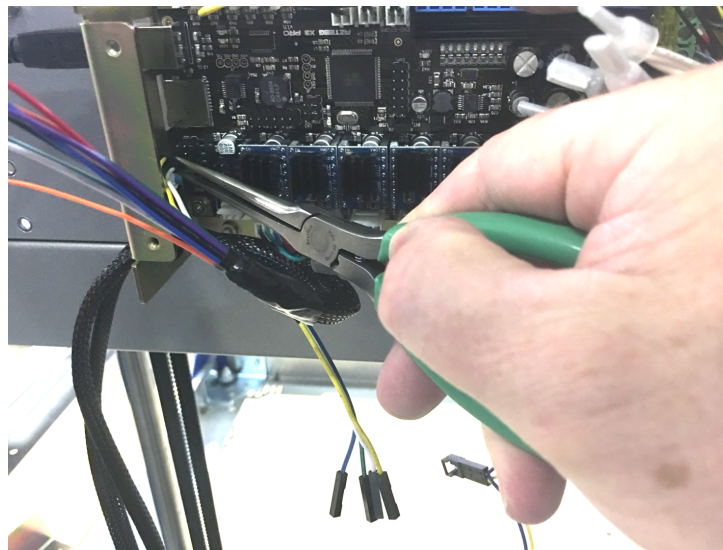

Step 6. Reattach the controller housing cover

Before you put the cover back on, please double check that all of the wires are attached to the correct pins. If any wires have been placed upon an incorrect pin, the LCD Smart Controller will not function normally. As you reattach the cover, be sure that the wires are clear of the three cooling fans.

Step 7. Attach cables to the LCD Smart Controller

On the back of the LCD Smart Controller, attach the Universal Cable and the 4-pin cable. Also, verify that the jumper is set to 5v. The position of the cables is crucial, so use the graphic below as a guide.

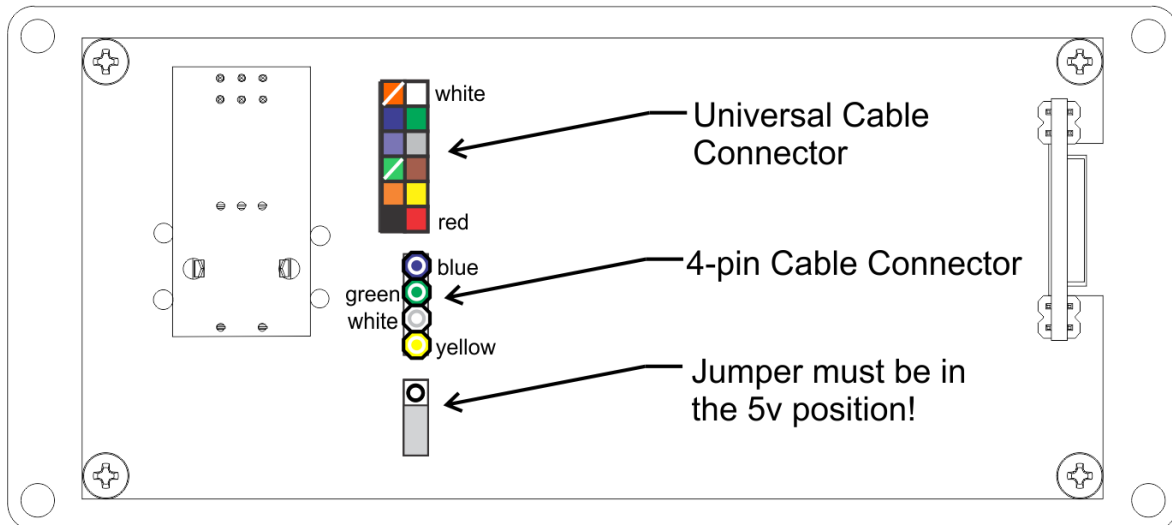

Step 8. Attach Housing to the LCD Smart Controller or print an LCD Mount

The all metal housing may not have shipped with your Smart Controller. If so, the housing will ship separately and will include a separate user guide. We are expecting the new housings to arrive by late December 2015, and we will send them out as soon as possible. Until then, please print the LCD Smart Controller Brackets from the Kickstarter support page if you want to start using your Smart Controller immediately. You can download a printable LCD Smart Controller Bracket at

- <http://stacker3d.com/kickstarter-support>

The printed bracket is attached to the back of the LCD Controller as shown below by using the provided hardware.

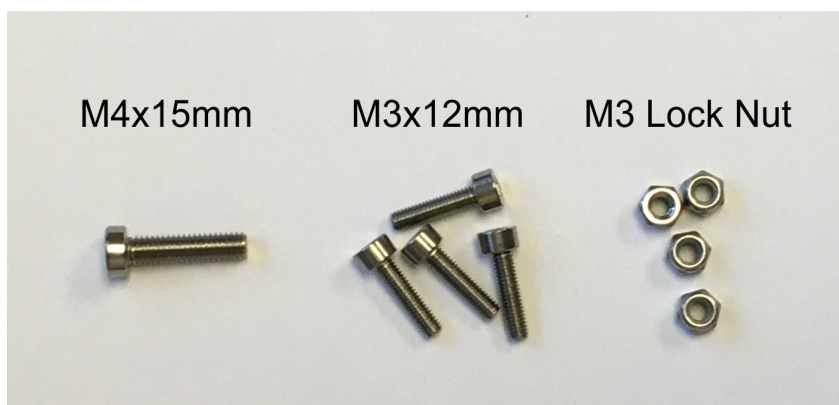

To mount the LCD Smart Controller directly to your printer, you can remove a screw from the top of your printer, as shown below, and attach the bracket with the M4x15mm screw.

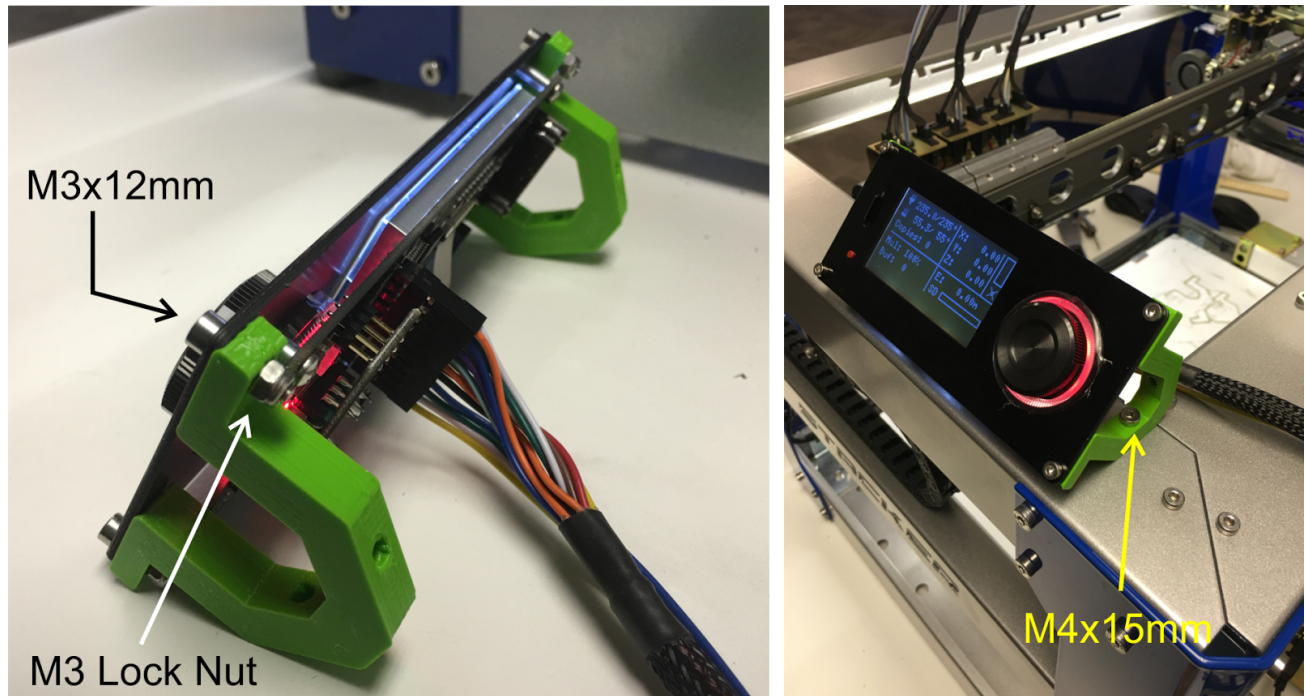

Step 9. Power up your printer

Reattach the power cable to your printer and turn the power switch on. Verify that all three of the controller housing cooling fans are operational. If you hear a loud noise it is probably a wire connector making contact with one of the cooling fans. If so, immediately turn off the power to prevent damage. Re-open the controller housing to adjust the wire locations and turn the power back on to verify that no wires are hitting fans in the controller housing.

WARNING! If your cooling fans are not functioning properly, your control board will overheat and be permanently damaged. The controller housing cooling fans are essential for your printer to function properly. Always check your fans before printing.

Step 10. Using the LCD Smart Controller

The best way to get familiar with your new LCD Smart Controller is by using it. If you notice some functions do not work, you should return to step 4 above and verify the connections on your controller board.



STATIC DISCHARGE WARNING! Always touch the frame of your printer to discharge any static electricity before touching the LCD Smart Controller. In rare cases, static electricity can cause the LCD Smart Controller to malfunction or reset your printer.

By pushing and rotating the Large Encoder Knob, you can run through menus and make selections by pushing the large encoder knob.

Be sure to install the microSD card in the proper orientation. Note, once the LCD Smart Controller is installed, the microSD port on the controller housing will no longer function.

Also, if the dual LED ring is showing both red and blue it means that your printer is in an error state probably caused by having a heater block detached. Fix the issue and reset the controller with the Button Switch to clear the error state.

IMPORTANT: Pressing the Button Switch will reset your controller and stop the print!

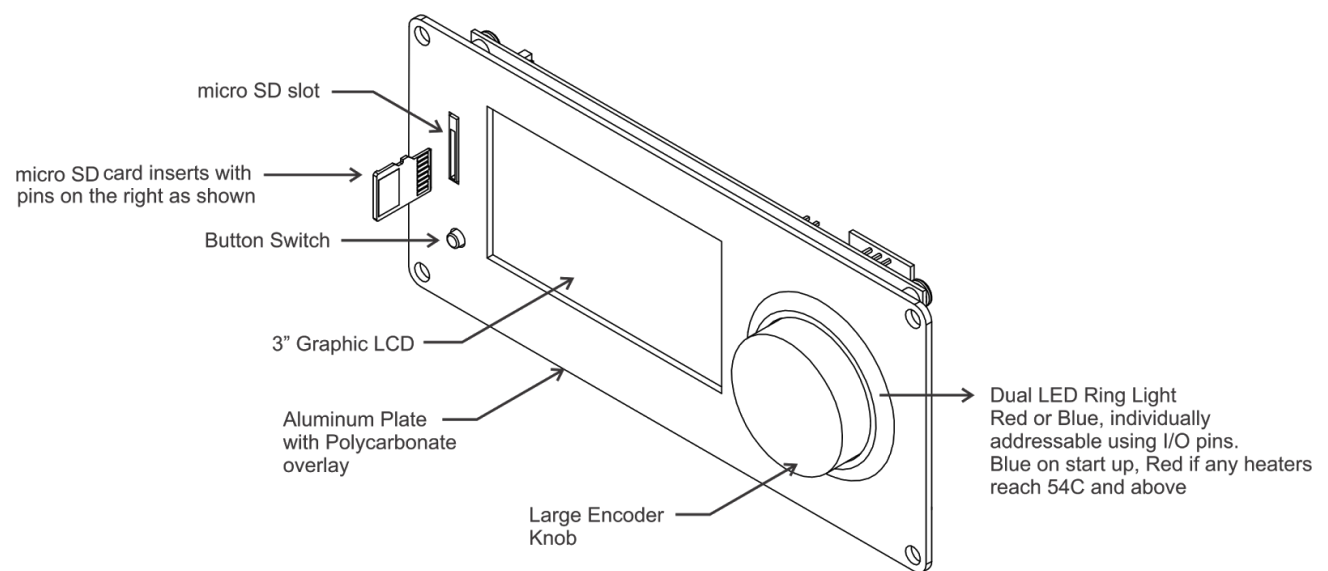

9.3 Filament Settings Reference

These are suggested settings for STACKER.

Filament	Nozzle Temp.	Bed Temp for Glass	Bed Temp for BuildTak	Fan
PLA/PHA	215°-225°	55°	45°-50°	Yes
XT	255°	65°-75°◆◆	50°-60°	No
nGen	235°-245°	65°-75°◆◆	50°-60°	No
Woodfill, Bamboofill	220°	55°	45°-50°	Yes
Brassfill, Bronzefill, Copperfill	225°	55°	45°-50°	Yes

◆◆Use glue Stick

10. Terms and Conditions

STACKER, LLC

TERMS AND CONDITIONS OF SALE & LICENSE

As used herein, "Seller" shall mean Stacker, LLC, a Minnesota limited liability company, or any wholly-owned subsidiary of Stacker, LLC.

These terms and conditions, and any applicable Seller quotation, sales order acknowledgement and Separate Software License, along with any other documents incorporated by reference in any of the foregoing (hereinafter collectively the "Agreement"), bind the buyer ("Buyer") and Seller as to any hardware products sold by Seller to Buyer ("Hardware"), any services sold by Seller to Buyer ("Services"), and any software (including without limitation, any embedded software) licensed or sublicensed by Seller to Buyer ("Software"), and constitute the entire agreement between Buyer and Seller regarding such sale and/or license.

Also as used herein and as applicable: (1) Hardware, Software and Services are collectively, and as applicable, referred to as "Goods" and (2) the term "Separate Software License" shall mean a set of terms and conditions that govern the licensing of specific Software and which is communicated to the Buyer by Seller or by a third party software owner.

This Agreement is subject and expressly limited to the terms and conditions contained in this Agreement. Any terms or conditions stated by the Buyer in any prior, concurrent and/or subsequent request for proposal, offer, purchase order and/or other documents are deemed by Seller to be a material alteration of this Agreement and are hereby rejected and inapplicable unless specifically agreed to in writing by an authorized representative of Seller. **Buyer shall be deemed to have accepted the Agreement and all of its terms and conditions, without exception, if any of the following events occur: (1) Buyer communicates to Seller its acceptance of the applicable Seller's quotation and/or sales documents; (2) Buyer issues Seller a purchase order which includes the same Goods and prices as set forth on the corresponding Seller's quotation and/or sales documents; and/or (3) Seller delivers any of the Goods covered by the applicable Seller's quotation and/or sales documents.**

1. **PRICES:** Except as otherwise set forth in writing by Seller, the price for Goods shall be as set forth in the applicable Seller's quotation and/or sales documents, or if the price is not set forth in any such quotation or documents, in accordance with Seller then-current list price. Prices set forth in a Seller's quotation shall be valid for thirty (30) days from the date of such quotation.
2. **SHIPPING, RISK AND TITLE:** All shipping dates are approximate and are based on Seller's prompt receipt of all necessary information from Buyer to properly process the order. Goods are shipped ExWorks Seller's facility (pursuant to Incoterms 2010). Subject to Section 8(a) below, title to the Goods and risk of loss thereto shall transfer to Buyer upon tender of the Goods to a carrier at Seller's factory. Buyer shall be responsible for all of the following related to the Goods: freight, duty and tax costs, risk, securing insurance, customs clearance and related costs, and arranging for a carrier and determining the method of shipment.
3. **TAXES AND DUTIES:** Prices do not include applicable taxes, duties or fees, including without limitation, any sales, excise, value added or goods sold taxes, or any customs duties or fees. Except for taxes due on Seller's net income, any taxes, duties or fees payable on any transactions hereunder shall be the responsibility of Buyer, and Seller may invoice Buyer for any such taxes, duties or fees that are or may be payable by Seller.
4. **PAYMENT:**
 - (a) Except as otherwise required by Seller in its sole discretion (e.g., payment in advance, payment by letter of credit), Buyer agrees to pay Seller's invoice, in U.S. currency, net thirty (30) days from the invoice date.
 - (b) If any payment owed to Seller hereunder is not paid when due, Seller may charge Buyer a late payment charge of one and one-half percent (1½%) per month or, if less, the maximum rate allowed by law, on all past outstanding balances. In the event Buyer fails to make any payment when due, Seller shall have the right, among other remedies, to terminate this Agreement or to suspend further delivery of Goods under this and/or other agreements with Buyer. Buyer shall be liable to Seller for all expenses attendant to collection of any past due amounts, including without limitation, reasonable attorneys' fees.

- (c) Seller reserves a purchase money security interest in the Goods sold only to the extent of the invoiced amount and solely for the purpose of securing Buyer's payment obligation hereunder. This Agreement is a security agreement. At Seller's request, Buyer agrees to promptly execute any instrument or statement, and otherwise cooperate with Seller, in order to perfect the aforesaid security interest; provided, however, that in the event Buyer fails to comply with any such request, Buyer authorizes Seller, or a representative on behalf of Seller, to sign and file the necessary instruments or statements for the Buyer.
5. **DOCUMENTATION:** Seller shall provide Buyer with that data/documentation that: (1) is specifically identified in the applicable Seller's quotation and/or order documents; and (2) is made commercially available and provided by Seller with the applicable Goods in Seller's normal course of business.
 6. **RECEIVING:** Except as set forth in the applicable Seller quotation and/or other applicable Seller documentation provided with the Goods, Buyer shall be responsible for receiving, storing, installing, starting up and maintaining all Goods.
 7. **CANCELLATION:** Buyer may cancel its order at any time prior to shipment by providing written notice thereof to Seller and paying Seller liquidated damages in the following amounts: (a) if the order is cancelled within 10 calendar days of the Buyer's purchase order date, then an amount equal to twenty-five percent (25%) of the total order price; (b) if the order is cancelled within 11 to 30 calendar days of the Buyer's purchase order date, then an amount equal to fifty percent (50%) of the total order price; and (c) if the Buyer's order is cancelled between 31 and 60 days of the Buyer's purchase order date, then an amount equal to seventy-five percent (75%) of the total order price. The parties agree that actual damages stemming from any order cancellation will be difficult to calculate and as such the parties agree that the aforesaid amounts do not represent a cancellation penalty, but rather a reasonable and good faith estimate of the actual damages incurred as a result of the cancellation. To the extent Buyer has made any payments prior to cancellation, Seller may apply any payments against any liquidated damages or other amounts due Seller under this Agreement.
 8. **RETURNS:**
 - (a) **Allowable Period:** For all electronic items, the Seller will accept returns only within ten (10) calendar days from the date of the Buyer's receipt of merchandise, subject to a 10% restocking fee. For non-electronic items, excluding filament, the Seller accepts returns only on unopened items within thirty (30) calendar days from the date of Buyer's receipt of merchandise. Filament may not be returned.
 - (b) **Return Process:** The Buyer shall arrange and pay all shipping, freight, and customs, taxes, and duties related to returning merchandise to the Seller. For credit, all merchandise must be returned in its original packaging. The customer must contact the Seller to be issued a return authorization account (RMA) number. Any returns made by a Buyer without a return authorization account number will be considered an "Unauthorized Return" and will not be subject to a refund or credit by the Seller. If the returned product is not received by the Seller in "Resalable Condition", the Buyer may not receive credit. "Resalable condition" means the Product has no sign of: use, wear and tear, cosmetic damage, or any other damage; furthermore, the Buyer is responsible for any damage to the returned product incurred during the shipping.
 9. **SOFTWARE:**
 - (a) Seller and/or any applicable third party owner shall retain exclusive right, title and ownership in and to their respective Software, and the license provided herein does not convey to Buyer any interest in the Software or any part thereof. Buyer acknowledges and agrees that the Software consists of proprietary material and information of Seller and/or any applicable third party owner, and is protected under U.S. and foreign copyright and other intellectual property laws, as well as international treaty provisions.
 - (b) If a Separate Software License is provided with the Software, referenced on Seller order documents and/or otherwise communicated to Buyer, then such Software shall be governed, in order of precedence, by the terms of the Separate Software License and then by any non-conflicting terms hereof. If no Separate Software License applies, then Seller hereby grants to Buyer, and Buyer accepts, a limited, personal, non-exclusive license, without the right to sublicense, to use the Software only: (1) with the specific Seller's manufactured Hardware that such Software is intended to operate with; or (2) if the Software is not intended to operate with Seller's manufactured Hardware, on a single computer owned, leased or otherwise controlled by the Buyer. Any concurrent use of the Software and any use on any local area network or other type of network are not authorized. Notwithstanding any term in this Section 8(b) to the contrary, Buyer's license rights in the Software shall include the right to use the Software in any manner expressly described in any Seller supplied documentation as described in Section 5 above.

(c) Except as required to be permitted by applicable law, Buyer may not copy, reverse engineer, decompile, disassemble or modify the Software in any way. The aforesaid Software license does not entitle Buyer to any Software source code.

(d) Repair of Software may be in the form of available corrections, fixes and/or patches to address Software bugs or inconsistencies, and/or to address non-conformance with the applicable Software specifications (collectively "Updates"). Following expiration of the Software warranty, Updates available from Seller shall be provided to Buyer either: (1) in accordance with Seller's quoted price therefore; or (2) at no charge if Seller provides such specific Updates at no-charge on a commercial basis to all of its customers. Seller shall not be required to make available any new versions and/or releases of any Software that provide new and/or enhanced features, performance and/or capabilities for the Software ("Upgrades"). In the event Seller does, in its sole discretion, make any Upgrades available, such Upgrades shall be subject to Seller quoted price therefore. As used in this Agreement, Software shall include any Updates and Upgrades made thereto.

(e) Notwithstanding any term or provision in this Agreement to the contrary, and with respect to any Software and/or any part thereof for which the intellectual property rights are not owned by Seller, including any third party commercial software and any software commonly referred to as open source code or open source software (collectively "Third Party Software"): (1) any such Third Party Software shall be governed exclusively by the Third Party Software owner's applicable license terms if such terms are provided with or as part of the Third Party Software; (2) nothing in this Agreement, a Separate Software License or any other agreement shall restrict or otherwise affect any rights and/or obligations Buyer may have, or conditions to which Buyer may be subject to, under any open source licenses to any open source code or software provided in or with the Software; and (3) Seller provides no warranty of any kind, express or implied, with respect to any such Third Party Software, which is provided "AS IS"; provided, however that Buyer may avail itself to any warranty provided by the supplier of any such Third Party Software.

(f) The aforesaid Software license(s) shall be non-transferable except as follows: (1) any embedded Software that is included in and intended to operate with any Hardware shall be transferable with the transfer of the Hardware to another party provided that such transfer is on terms that do not materially conflict with the Software license terms in this Agreement; and (2) for Software that is not embedded Software, Buyer shall have a permanent right to transfer all its Software rights under this Agreement to another party, provided Buyer passes all the copies of the Software licensed to the other party along with the accompanying documentation and a copy of this Agreement, and provided that the other party accepts the terms of this Agreement. If you transfer the Software as permitted herein, you may not retain any copies of the Software for your own use and your license rights under this Agreement are terminated.

(g) The aforesaid Software license(s) shall continue until and automatically terminate upon Buyer's breach of any of the terms hereof.

10. **LIMITED WARRANTY:** With respect to all Goods, the following warranty terms ("General Warranty Terms") shall apply solely during the applicable warranty period set forth in Sections 9(a) through 9(f) below. If Buyer has used the Goods under normal use and care and discovers any defects in material or workmanship, or any material deviation from the Goods' applicable published specifications, and notifies Seller in writing thereof during the applicable warranty period, Seller shall, at its option, use reasonably commercial efforts to repair or replace that portion of the Goods found by Seller to be defective in material or workmanship, or in material deviation from the applicable specifications, or refund the purchase price of such Goods. Any Goods to be returned to Seller for repair or replacement under this warranty must be returned to Seller's designated facility and in accordance with Seller's then-current return material authorization (RMA) procedures and Buyer must contact Seller and obtain a RMA number and such procedures prior to any such return. This limited warranty shall not apply in the event any such defects and/or deviations are based in whole or part by improper or inadequate maintenance, unsuitable power sources or environmental conditions, improper maintenance, alteration or modification by any party other than Seller or its authorized representative, storage or handling, accident, repair by a party other than Seller or its authorized representative, or any other cause not the fault of Seller. Except as expressly set forth in this limited warranty, all costs incurred by Buyer relating to or arising out of this warranty, including without limitation, those related to dismantling and reinstallation of the Goods, shall be borne by Buyer. Except as expressly agreed to in writing by Seller prior to shipment, Seller makes no warranty or representation that the Goods supplied hereunder comply with any local laws, rules, regulations or ordinances, and Buyer shall be responsible for obtaining all permits, licenses, authorizations and/or certificates required by any regulatory body for installation or use of the Goods. This limited

warranty is the only warranty made by Seller, and SELLER DOES NOT WARRANT THAT THE USE OF THE GOODS OR ANY PARTS THEREOF WILL BE UNINTERRUPTED OR ERROR FREE, AND THERE ARE NO OTHER WARRANTIES OR REPRESENTATIONS OF ANY KIND WITH RESPECT TO THE GOODS OR ANY PARTS THEREOF, EXPRESS OR IMPLIED, INCLUDING WITHOUT LIMITATION, THOSE OF MERCHANTABILITY, FITNESS FOR A PARTICULAR PURPOSE OR NON-INFRINGEMENT.

- (a) Hardware (including embedded Software therein) is warranted for a period of twelve (12) months from the date of shipment by Seller.
- (b) Notwithstanding the foregoing, the following parts ("Wear Parts") are warranted for a period of forty five (45) days: 1) filament drive gears, 2) filament guide tubes and hot ends. Hot ends include the following components: 1) heater cartridges, 2) heater blocks, 3) thermistors, and 4) PTFE filament guide tubes. Adhesive print bed coatings or sheets and glass print beds carry no warranty.
- (c) Services are warranted for a period of ninety (90) days from the date the Services are provided by Seller.
- (d) Notwithstanding any of the foregoing, Goods repaired or replaced during the warranty period, or Goods identified as rebuilt regardless of when purchased, are warranted for the longer of the remainder of the original warranty period or ninety (90) days from the date of shipment by Seller.
- (e) Software is warranted for a period of ninety (90) days from the date of "shipment". As used herein, "shipment" shall mean either: (1) the date the Software is physically shipped by Seller to Buyer (with or without Hardware); or (2) the date the Software is electronically transmitted to Buyer by Seller.
- (f) No warranty is extended with respect to third party owned software. Notwithstanding any language in this limited warranty to the contrary, Seller shall have the right to discontinue the availability of any Goods or components or replacement parts therefore, or to make design changes or improvements in the Goods at any time and such discontinuance or change shall not constitute a breach of warranty, or result in any liability or obligation to Seller whatsoever, including, without limitation, any obligation to retrofit, change or improve Goods purchased by Buyer prior to the discontinuance or change.

11. **LIMITATION OF REMEDY AND LIABILITY:** THE SOLE AND EXCLUSIVE REMEDY FOR BREACH OF WARRANTY HEREUNDER SHALL BE LIMITED TO REPAIR, REPLACEMENT OR REFUND UNDER THE LIMITED WARRANTY SET FORTH IN SECTION 9 ABOVE. IN NO EVENT, REGARDLESS OF THE FORM OF THE CLAIM OR CAUSE OF ACTION (WHETHER BASED IN CONTRACT, INFRINGEMENT, NEGLIGENCE, STRICT LIABILITY, OTHER TORT OR OTHERWISE), SHALL SELLER'S LIABILITY TO BUYER AND/OR BUYER'S CUSTOMERS EXCEED THE PRICE TO BUYER OF THE SPECIFIC GOODS PROVIDED BY SELLER GIVING RISE TO THE CLAIM OR CAUSE OF ACTION. BUYER AGREES THAT IN NO EVENT, SHALL SELLER'S LIABILITY TO BUYER AND/OR BUYER'S CUSTOMERS EXTEND TO INCLUDE INCIDENTAL, CONSEQUENTIAL OR PUNITIVE DAMAGES. THE TERM "CONSEQUENTIAL DAMAGES" SHALL INCLUDE, WITHOUT LIMITATION, LOSS OF ANTICIPATED REVENUE OR PROFITS, LOSS OF USE OR DATA, DAMAGES BASED ON ANY DELAY IN PERFORMANCE, AND CLAIMS OF BUYER'S CUSTOMERS. SELLER AND BUYER AGREE THAT THE LIMITATIONS SET FORTH IN THIS PROVISION SHALL BE ENFORCED TO THE MAXIMUM EXTENT PERMITTED BY APPLICABLE LAW. TO THE EXTENT PERMITTED BY APPLICABLE LAW, THE LIMITATIONS SET FORTH HEREIN SHALL EXTEND TO THE BENEFIT OF SELLER'S SUPPLIERS.

12. **CONFIDENTIAL INFORMATION.** Any information disclosed by Seller to Buyer related to this Agreement, including quotations, pricing, technical information or otherwise, shall be deemed "Confidential Information". Buyer shall not disclose any Confidential Information to any third parties without Seller's prior written consent and shall use such Confidential Information only for the purposes reasonably related to the purchase and use of Seller's Goods. Seller shall, at all times, retain all right, title and interest in the Confidential Information and all copies thereof.

Notwithstanding the foregoing, Confidential Information shall not include information which is or becomes publicly known through no wrongful act of Buyer.

13. **GOVERNING LAW / DISPUTES:**

(a) This Agreement shall be construed, performed and enforced under the laws of the State of Minnesota, U.S.A.

(b) If Buyer's address is in the United States, the sole and exclusive venue for any claims or actions under or related to this Agreement shall be in the applicable court(s) in the city of Minneapolis, Minnesota, U.S.A. If Buyer's address is not located in the United States, then Seller and Buyer agree that any controversy or claim arising out of or relating to this Agreement shall be determined by arbitration in accordance the then-current rules of the American Arbitration Association by one or more arbitrators appointed in accordance with said rules, and

such arbitration shall be conducted in the city of Minneapolis, Minnesota, U.S.A. Notwithstanding the foregoing, either party may, at anytime, apply to a court having jurisdiction for a preliminary injunction and/or other equitable relief where such relief is necessary to protect the party's interests pending completion or anticipated beginning of any arbitration.

(c) This Agreement shall be interpreted and construed in the English language and any proceedings and/or arbitration conducted hereunder shall be in English.

(d) Notwithstanding the foregoing, if applicable law requires that any of the terms and conditions set forth in the Agreement be different than those set forth in the Agreement, including without limitation, the governing law, arbitration and/or other dispute resolution terms set forth in this Section 14, then the Agreement shall be deemed modified and amended to the minimal extent necessary to comply with and incorporate such applicable law, and the rest of the terms and conditions of the Agreement, as so amended, shall continue in full force and effect.

14. **GENERAL PROVISIONS:**

(a) Except as expressly set forth in this Agreement, Buyer may not assign this Agreement, or any rights or obligations hereunder, without Seller's prior written consent.

(b) No action, regardless of form, arising out of or related to this Agreement, may be brought by Buyer more than two (2) years after the cause of action has accrued.

(c) Seller shall not be liable for delays in performance or for non-performance due to acts of God, war, terrorism, riot, fire, labor trouble, unavailability of materials or components, accident, compliance with governmental laws, rules, regulations, orders or requests, or any other circumstances or causes beyond Seller's reasonable control.

(d) In the event any of the terms of this Agreement are in conflict with any rule of law or statutory provision, or are otherwise unenforceable under any applicable laws or regulations, such terms shall be enforced to maximum extent permitted by the applicable laws or regulations, and to the extent unenforceable, such terms shall be deemed stricken from this Agreement, but such invalidity or unenforceability shall not invalidate any of the other terms of this Agreement.

(e) No failure by Seller to take any action or assert any right hereunder shall be deemed to be a waiver of such right in the event of the continuation or repetition of the circumstances giving rise to such right.

(f) Any modification of these terms and conditions must be set forth in a written instrument signed or issued by duly authorized representative of Seller.

(g) This Agreement is the entire agreement between the parties with respect to the subject matter herein and supersedes all oral and written communications regarding the subject matter hereof. There are no understandings, agreements or representations, express or implied, not specified in the Agreement.

Notes: